

# CILINDRO SERIE "ISO 15552" (EX ISO 6431) Ø 32÷125 mm

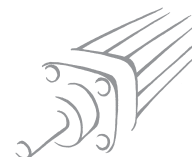

1

Cilindros realizados de conformidad con la norma ISO 15552; disponibles en varias versiones y con una amplia gama de accesorios:

- ejecución con o sin detección magnética
- simple efecto y doble - vástago simple o pasante
- posibilidad de elegir entre juntas en NBR, POLIURETANO y FKM/FPM (para altas temperaturas)
- ejecuciones especiales a petición
- accesorios de fijación, unidad de guía y de bloqueo mecánico de vástago



DATOS TÉCNICOS	POLIURETANO	NBR	FKM/FPM	Baja Temperatura
Presión de trabajo	máx 10 bar (máx 1 MPa - 145 psi)			
Temperatura de funcionamiento Ø 32 ÷ 63	-20°C ÷ +80°C (Cil. no magnético)	-10°C ÷ +80°C (Cil. no magnético)	-10°C ÷ +150° (Cil. no magnético)	-35°C ÷ +80°C
	-20°C ÷ +70°C (Cil. magnético)	-10°C ÷ +70°C (Cil. magnético)		
Ø 80 ÷ 125	-10°C ÷ +80°C (Cil. no magnético)	-10°C ÷ +80°C (Cil. no magnético)	-10°C ÷ +150° (Cil. no magnético)	-35°C ÷ +80°C
	-10°C ÷ +70°C (Cil. magnético)	-10°C ÷ +70°C (Cil. magnético)		
Fluido	Aire sin lubricación, si se utiliza aire lubricado la lubricación debe ser continua			
Diámetros	Ø 32 ; Ø 40 ; Ø 50 ; Ø 63 ; Ø 80 ; Ø 100 ; Ø 125			
Tipo de construcción	Culatas con tornillos autoformantes			
Carreras standard †	Simple efecto: para diámetros de Ø 32÷63 carreras de 0 a 250 mm Efecto doble: para diámetros de Ø 32÷80 carreras de 25 a 2800 mm para diámetros de Ø 100÷125 carreras de 25 a 2600 mm			
Versiones	Doble efecto amortiguado, Simple efecto vástago retraído amortiguado, Vástago pasante amortiguado, Amortiguamiento prolongado, Alta temperatura, Bloqueo de vástago, Estanqueidad aceite, Vástago pasante estanqueidad aceite, Bajo rozamiento, Anti skip-slip.			
Imanes para sensores	Todas las versiones con detección magnética a petición suministrado sin detección			
Presión de arranque	Ø 32;40: 0.4 bar Ø 50;63 carrera < 1500 mm: 0.3 bar; carrera ≥ 1500 mm: 0.4 bar Ø 80;100;125 carrera < 1500 mm: 0.2 bar; carrera ≥ 1500 mm: 0.4 bar			
Fuerza a desarrollar a 6 bar en empuje/tracción	Ver DATOS TECNICOS GENERALES PAG. 1.1/05			
Peso	Ver DATOS TECNICOS GENERALES PAG. 1.1/06			
	Para versiones anti stick slip utilizar sólo aire sin lubricación			
	† carreras máximas aconsejables, valores superiores pueden crear problemas de funcionamiento.			

## COMPONENTES

- ① VÁSTAGO: acero C45 o inox. cromado en profundidad
- ② CULATAS: en aluminio fundido a presión
- ③ JUNTAS VÁSTAGO: en poliuretano NBR o FKM/FPM
- ④ CASQUILLO DE GUIA: Fleje de acero con recubrimiento de bronce y PTFE
- ⑤ CAMISA: en aluminio prefilado anodizado
- ⑥ PISTON: en tecnopolímero autolubrificante con ojiva de amortiguación integrada (en aluminio con patín de PTFE para los diámetros 80-100-125)
- ⑦ JUNTAS PISTON: Poliuretano, NBR o FKM/FPM
- ⑧ IMANES: en plastoferrita
- ⑨ BUFER + OR estáticos: NBR o FKM/FPM
- ⑩ JUNTAS AMORTIGUACION: Poliuretano NBR o FKM/FPM
- ⑪ PUNZON: de amortiguación en OT 58 con sistema de seguridad escape punzón con total apertura
- ⑫ TORNILLOS: de ensamblaje automático autoformantes (Top Tite)

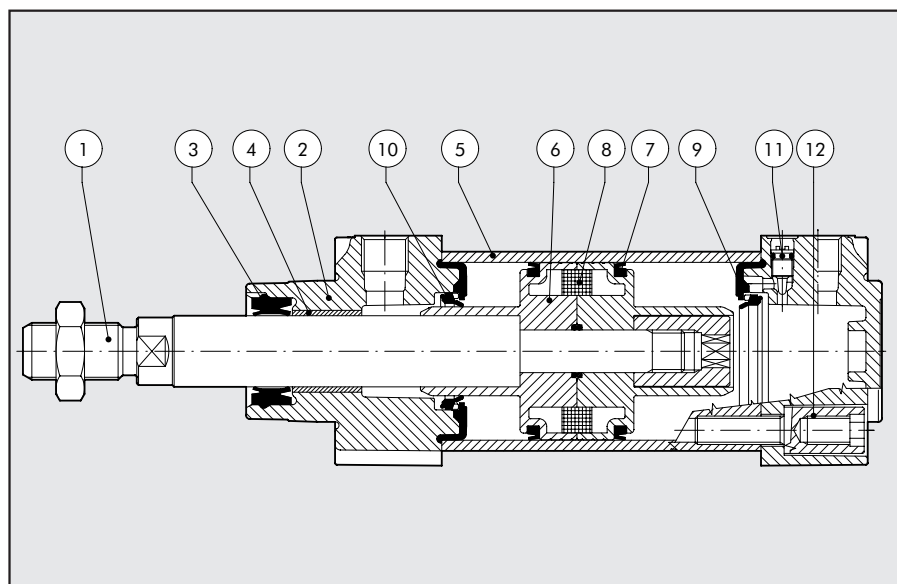

### DIMENSIONES VERSIONES STANDARD

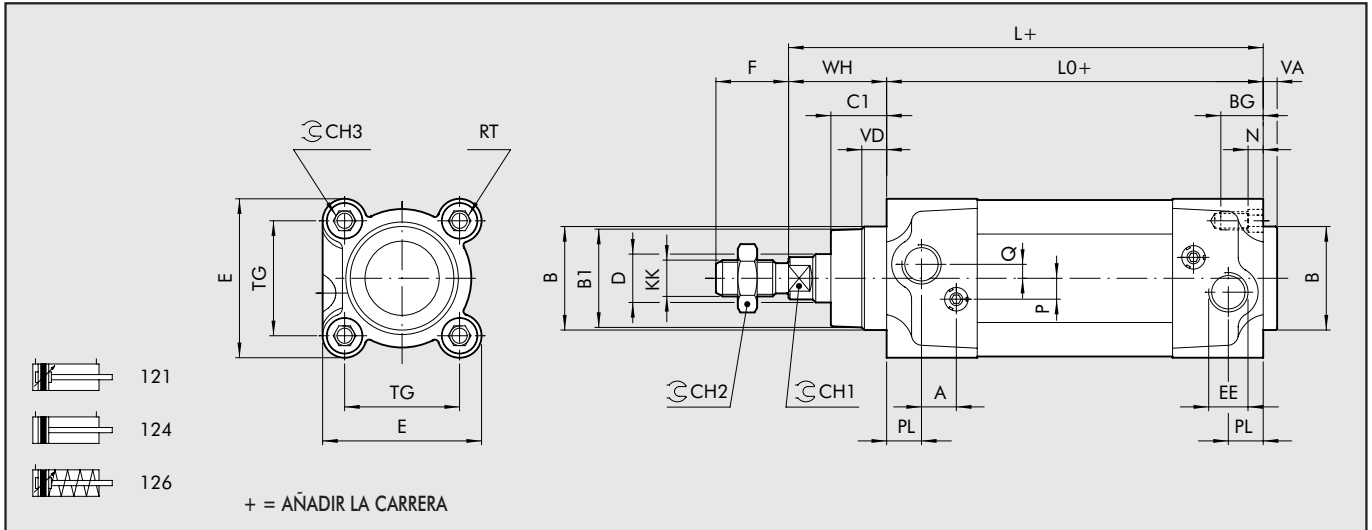

### DIMENSIONES VERSION VÁSTAGO PASANTE

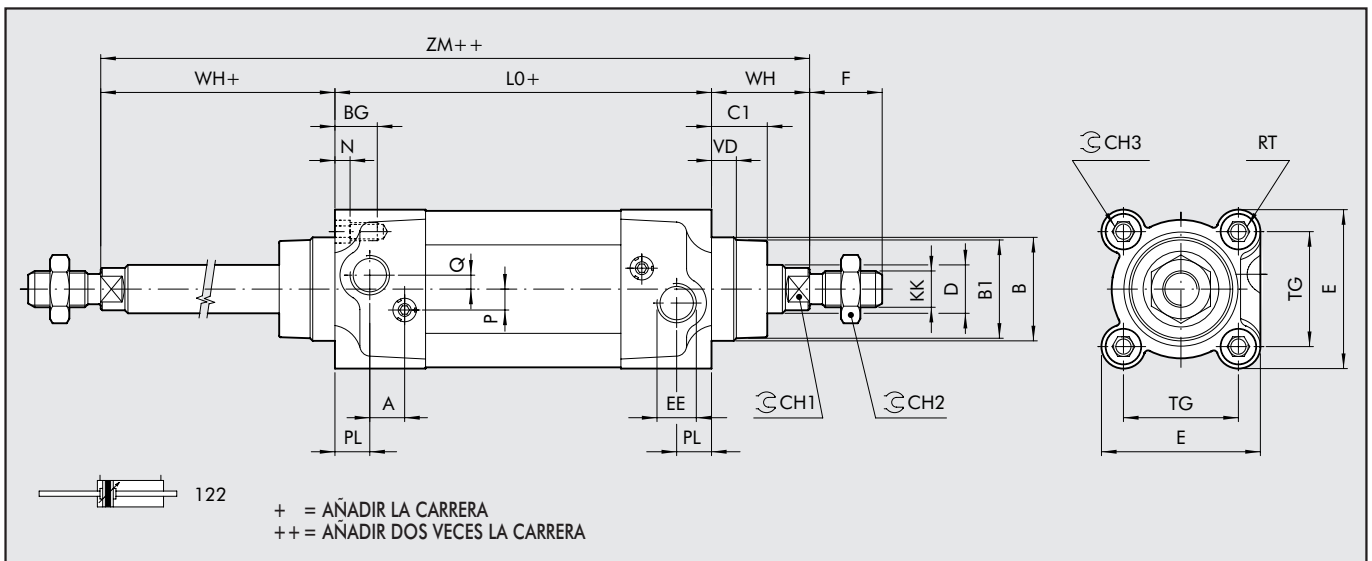

Ø	PL	VD	A	B	B <sub>1</sub>	WH	C <sub>1</sub>	CH <sub>1</sub>	CH <sub>2</sub>	CH <sub>3</sub>	KK	D	TG	VA	F	EE	RT	E	L	L <sub>0</sub>	ZM	BG	N	P	Q
32	10	6.5	10	30	28	26	16	10	17	6	M10x1.25	12	32.5	4	22	G1/8	M6	46	120	94	146	14.5	4.5	6	4
40	12	8	10	35	33	30	20	13	19	6	M12x1.25	16	38	4	24	G1/4	M6	54	135	105	165	14.5	4.5	6	4
50	14	13	10	40	38	37	25	17	24	8	M16x1.5	20	46.5	4	32	G1/4	M8	64.5	143	106	180	17.5	5.5	6	6
63	16	14	10	45	40	37	25	17	24	8	M16x1.5	20	56.5	4	32	G3/8	M8	75.5	158	121	195	17.5	5.5	6	6
80	18	12	12	45	43	46	33	22	30	10	M20x1.5	25	72	4	40	G3/8	M10	94	174	128	220	21.5	5.5	10	7
100	20	14	12	55	49	51	38	22	30	10	M20x1.5	25	89	4	40	G1/2	M10	111	189	138	240	21.5	5.5	10	7
125	25	20	10	60	54	65	45	27	41	12	M27x2	32	110	6	54	G1/2	M12	135	225	160	290	25.5	6.5	12	8

### VERSION 126 (SIMPLE EFECTO)

	Limite infer.	Carrera	Limite super.	L0 - Ø 32	L0 - Ø 40	L0 - Ø 50	L0 - Ø 63	L - Ø 32	L - Ø 40	L - Ø 50	L - Ø 63
ISO	0	< C ≤	25	94	105	106	121	120	135	143	158
ISO	25	< C ≤	50	94	105	106	121	120	135	143	158
NON ISO	50	< C ≤	75	115	129.5	130.5	145.5	141	159.5	167.5	182.5
NON ISO	75	< C ≤	100	136	154	155	170	162	184	192	207
NON ISO	100	< C ≤	125	157	178.5	179.5	194.5	183	208.5	216.5	231.5
NON ISO	125	< C ≤	150	178	203	204	219	204	233	241	256
NON ISO	150	< C ≤	175	199	227.5	228.5	243.5	225	257.5	265.5	280.5
NON ISO	175	< C ≤	200	220	252	253	268	246	282	290	305
NON ISO	200	< C ≤	225	241	276.5	277.5	292.5	267	306.5	314.5	329.5
NON ISO	225	< C ≤	250	262	301	302	317	288	331	339	354



## DIMENSIONES LARGA AMORTIGUACIÓN 100 mm

1

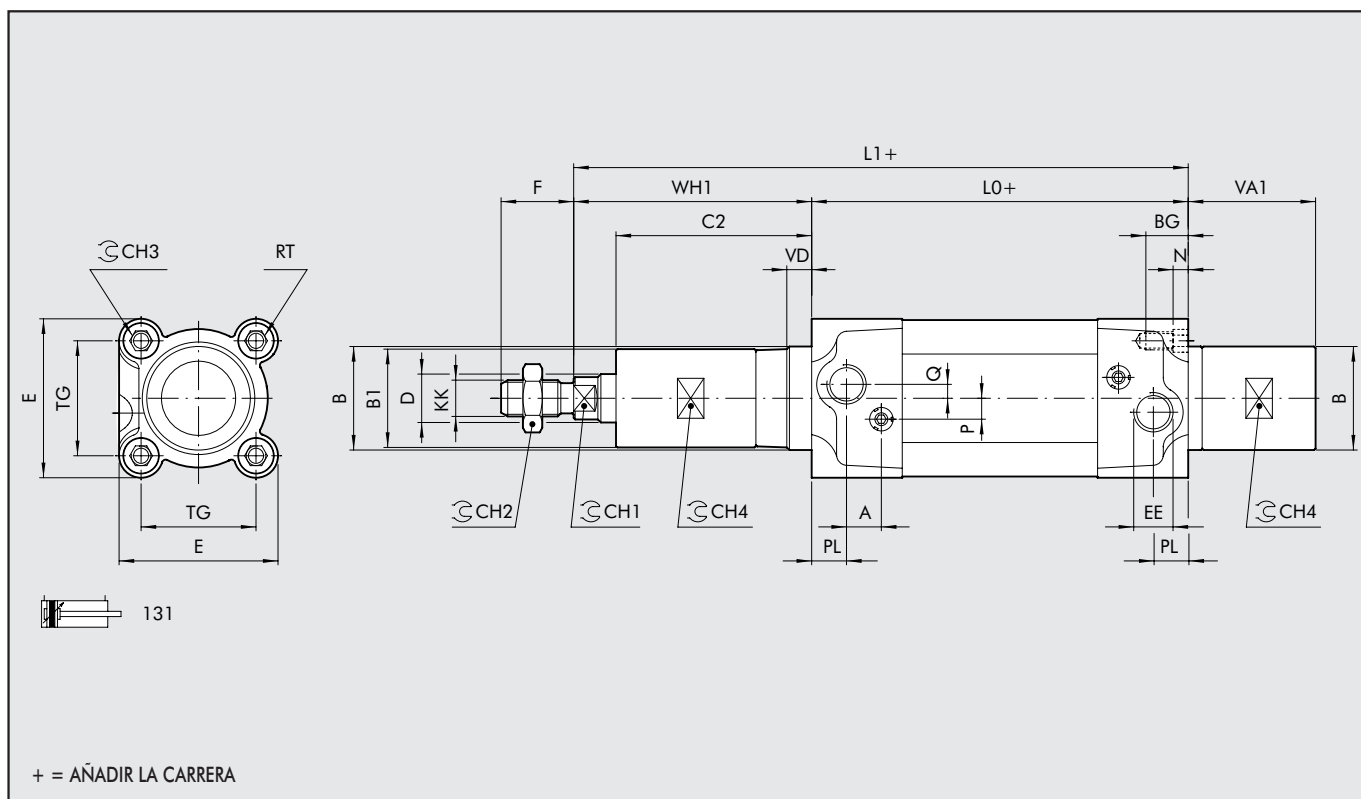

Ø	PL	VD	A	B	B <sub>1</sub>	WH <sub>1</sub>	C <sub>2</sub>	CH <sub>1</sub>	CH <sub>2</sub>	CH <sub>3</sub>	CH <sub>4</sub>	KK	D	TG	VA <sub>1</sub>	F	EE	RT	E	L <sub>1</sub>	L <sub>0</sub>	BG	N	P	Q
32	10	6.5	10	30	29	106	96	10	17	6	27	M10x1.25	12	32.5	279	22	G1/8	M6	46	200	94	14.5	4.5	6	4
40	12	8	10	35	34	107	97	13	19	6	30	M12x1.25	16	38	76.5	24	G1/4	M6	54	212	105	14.5	4.5	6	4
50	14	13	10	40	38	113.5	101.5	17	24	8	35	M16x1.5	20	46.5	76.5	32	G1/4	M8	64.5	219.5	106	17.5	5.5	6	6
63	16	14	10	45	38	113.5	101.5	17	24	8	35	M16x1.5	20	56.5	76.5	32	G3/8	M8	75.5	234.5	121	17.5	5.5	6	6

## DIMENSIONES LARGA AMORTIGUACIÓN 150 mm

## DIMENSIONES LARGA AMORTIGUACIÓN 200 mm

Ø	WH <sub>1</sub>	C <sub>2</sub>	VA <sub>1</sub>	L <sub>1</sub>
32	156	146	129	250
40	157	147	121.5	262
50	162.5	150.5	119.5	268.5
63	162.5	150.5	123.5	283.5

Ø	WH <sub>1</sub>	C <sub>2</sub>	VA <sub>1</sub>	L <sub>1</sub>
32	206	196	179	300
40	207	197	176.5	312
50	213.5	201.5	176.5	319.5
63	213.5	201.5	176.5	334.5

### DIMENSIONES CILINDRO TANDEM

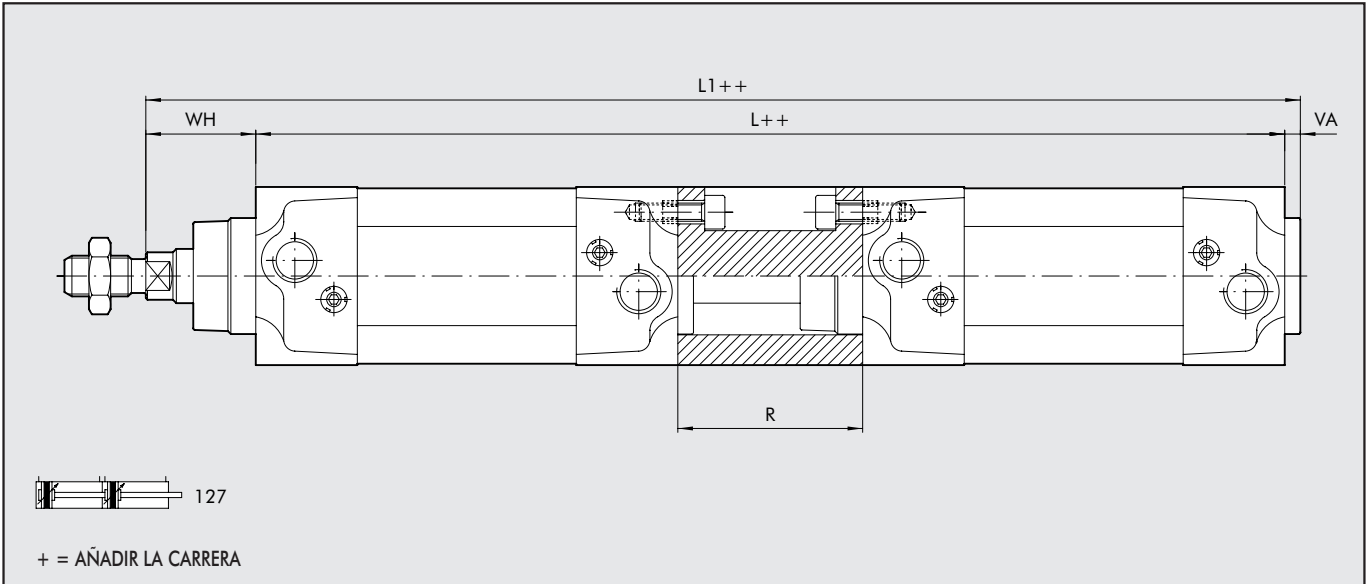

Ø	WH	VA	R	L	L <sub>1</sub>	
32	26	4	55	243	273	
40	30	4	55	265	299	
50	37	4	68	280	321	
63	37	4	68	310	351	
80	46	4	92	348	398	
100	51	4	92	368	423	
125	65	6	120	440	511	Para las cotas que faltan, hágase referencia a los cilindros standard

### DIMENSIONES CILINDRO CONTRAPUESTO

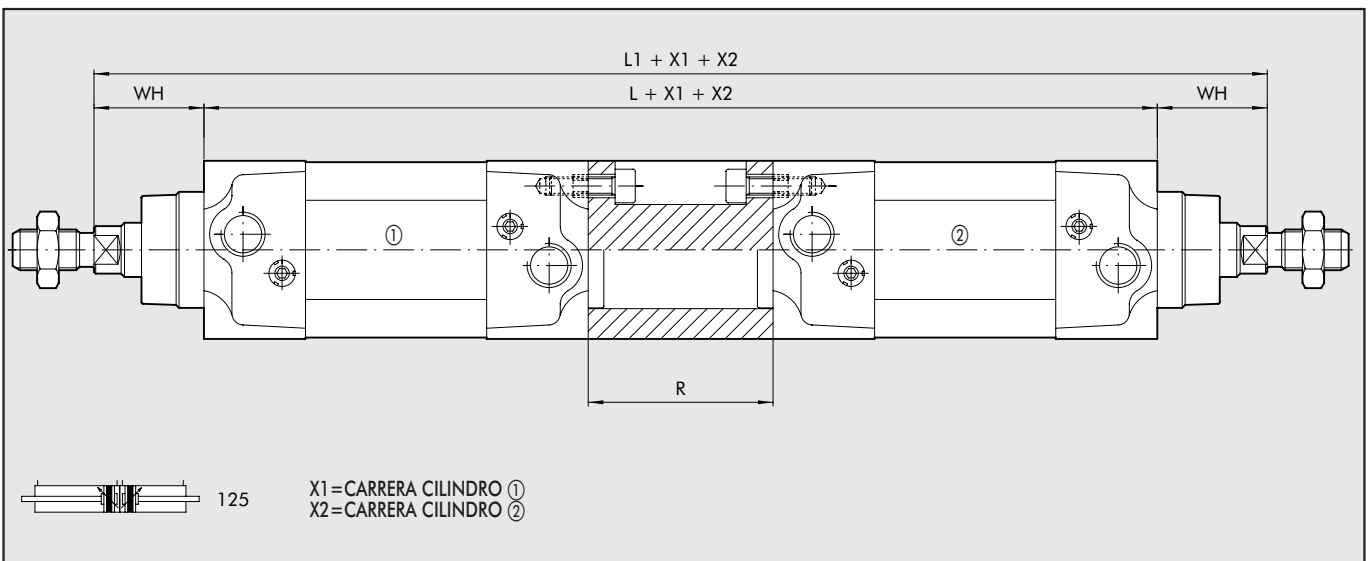

Ø	WH	R	L	L <sub>1</sub>	
32	26	55	243	295	
40	30	55	265	325	
50	37	68	280	354	
63	37	68	310	384	
80	46	92	348	440	
100	51	92	368	470	
125	65	120	440	570	Para las cotas que faltan, hágase referencia a los cilindros standard

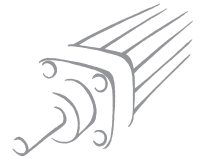

# CILINDRO DE BAJO ROZAMIENTO - COD. 123

1

- ① Juntas pistón cámara posterior en poliuretano ( $\text{Ø } 32 \div \text{Ø } 125$ );
- ② Juntas pistón cámara anterior en poliuretano ( $\text{Ø } 32 \div \text{Ø } 125$ );
- ③ Juntas amortiguación cámara posterior en poliuretano;
- ④ Juntas amortiguación cámara anterior en poliuretano;
- ⑤ Juntas, vástago en poliuretano

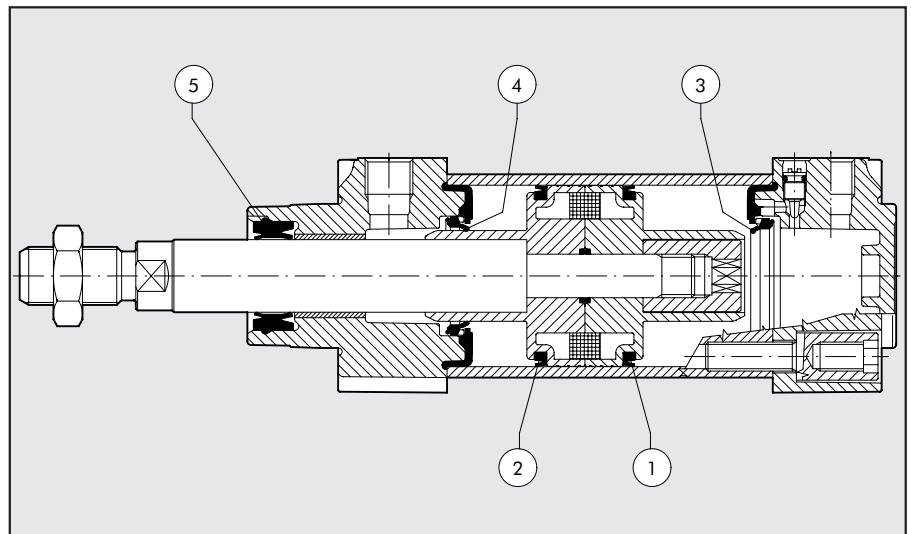

	Tipología	Juntas necesarias
Presión en cámara posterior	A	1
Presión en cámara posterior y amortiguación en caso de impacto	B	1+3
Presión en cámara posterior y juntas en vástago	C	1+5
Presión en cámara posterior, amortiguación en casos de impactos y juntas en vástago	D	1+3+5
Presión en cámara anterior	E	2+5
Presión en cámara anterior y amortiguación en caso de impactos	F	2+5+4

El uso típico del cilindro de bajo rozamiento debe considerarse en formas de cilindro bailarín o tensor; de hecho es un cilindro de simple efecto sin resorte de retorno. A continuación se indican varias posibilidades de ejecución:

- 1) La mejor tipología es la A, dado que es la que ofrece la menor fuerza de fricción.
- 2) La tipología B debe usarse en el caso en los cuales el cilindro trabaje en condiciones normales, fuera de la zona de amortiguación neumático; la amortiguación debe entenderse solamente para uso de emergencia (evitar los impactos en caso de averías).
- 3) La tipología C difiere de la A, por la presencia de la junta del vástago que impide la entrada de suciedad en ambientes poco limpios.
- 4) La tipología D difiere de la B por la presencia de la junta del vástago que impide la entrada de suciedad en ambientes poco limpios.
- 5) La tipología E debe usarse en el caso en que la cámara en presión sea la anterior.
- 6) En relación con la tipología F véase el punto 2.

NOTA: SE DEBE DE CONSIDERAR SIEMPRE COMO CILINDRO DE SIMPLE EFECTO, SIN MUELLE DE RETORNO.

## NOTAS

---



---



---



---



---



---



---



---



---



---



---



---



---



---



---



---



---



---



---



---



---



---

### CLAVES DE CODIFICACIÓN CILINDRO ISO 15552 STD

CIL	1	2	1	0	3	2	0	0	5	0	C	P		
	TIPOLOGIA			DIAMETRO			CARRERA							
120	Doble efecto amortiguado no magnético			0	Diámetro		Para carreras maximas ver en datos tecnicos			A	Vástago cromado C45 pistón de aluminio standard para todos los cilindros con carreras $\geq 1000$ mm y para cilindros a partir de $\varnothing 80$ mm		N	Juntas NBR
121	Doble efecto amortiguado			S	No magnético		32						P	Juntas Poliuretano
122	Vástago pasante			▲G	Grasa		40						V	Juntas FKM/FPM
124	Doble efecto no amortiguado				No stick slip		63						● B	Baja temperatura
125	Contrapuesto						80				C	C45 cromada pistón tecnopolimero: standard para cilindros desde $\varnothing 32$ a $\varnothing 63$ mm recorrido $< 1000$ mm		
+ 126	Simple efecto						■ 100				Z	Vástago y tuerca inox pistón en aluminio		
127	Tandem						■ 125				X	Vástago y tuerca inox. piston en tecnopolimero		
134	Version bloqueo de vástago													
136	Versión con bloqueo de vástago montado													
◆ 137	Bloqueo vástago + unida de guía													

■ Cuando la 4ª cifra esta ocupada por una letra  $\varnothing 100=A1$ ;  $\varnothing 125=A2$

● Disponible sólo para versión con pistón en aluminio (A o Z)

+ Disponible sólo para  $\varnothing 32-63$  y sólo versión con pistón en aluminio (A o Z)

▲ No disponible para versión NBR (N)

◆ Disponible sólo para  $\varnothing 32 \div 100$

### CLAVES DE CODIFICACIÓN CILINDRO ISO 15552 BAJO ROZAMIENTO

CIL	1	2	3	A	3	2	0	0	5	0	C	P
	TIPOLOGIA			DIAMETRO	CARRERA							
A	Bajo rozamiento tipo A			32	$\varnothing 32 \div 80$ carrera			A	Vástago C45 cromado pistón en aluminio: standard para todos los cilindros con carreras $\geq 1000$ mm y para cilindros a partir de $\varnothing 80$ mm		N	Juntas NBR
B	Bajo rozamiento tipo B			40	25 $\div$ 2800 mm						P	Juntas Poliuretano
C	Bajo rozamiento tipo C			50	$\varnothing 100 \div 125$ carrera						V	Juntas FKM/FPM
D	Bajo rozamiento tipo D			63	25 $\div$ 2600 mm			C	Vástago C45 cromado, pistón tecnopolimero: standard para cilindros a partir de $\varnothing 32$ a $\varnothing 63$ mm con carreras $< 1000$ mm			
E	Bajo rozamiento tipo E			80				Z	Vástago y tuerca inox. pistón de aluminio			
F	Bajo rozamiento tipo F			A1= $\varnothing 100$ A2= $\varnothing 125$				X	Vástago y tuerca inox. pistón en tecnopolimero			

### CLAVES DE CODIFICACIÓN CILINDRO ISO 15552 LARGA AMORTIGUACIÓN

CIL	1	3	1	A	3	2	0	0	5	0	Z	P
	TIPOLOGIA			DIAMETRO	CARRERA							
A	Cono amortiguación ant.-post. 200 mm - largo 200 mm			32	25 $\div$ 2600 mm			A	Vástago C45 cromado pistón en aluminio: para todos los cilindros		N	Juntas NBR
B	Cono amortiguación ant.-post. 150 mm - largo 150 mm			40							P	Juntas Poliuretano
C	Cono amortiguación ant.-post. 100 mm - largo 100 mm			50				Z	Vástago y tuerca inox. pistón de aluminio		V	Juntas FKM/FPM
D	Cono amortiguación ant.-post. 150 mm - largo 200 mm			63								
E	Cono amortiguación ant.-post. 100 mm - largo 200 mm											
F	Cono amortiguación ant.-post. 50 mm - largo 100 mm											
G	Cono amortiguación ant.-post. 100 mm - largo 150 mm											
H	Cono amortiguación ant. 200 mm - largo 200 mm											
I	Cono amortiguación ant. 150 mm - largo 150 mm											
L	Cono amortiguación ant. 100 mm - largo 100 mm											
M	Cono amortiguación ant. 150 mm - largo 200 mm											
N	Cono amortiguación ant. 100 mm - largo 150 mm											
O	Cono amortiguación ant. 50 mm - largo 100 mm											
Q	Cono amortiguación post. 200 mm - largo 200 mm											
R	Cono amortiguación post. 150 mm - largo 150 mm											
S	Cono amortiguación post. 100 mm - largo 100 mm											
T	Cono amortiguación post. 150 mm - largo 200 mm											
U	Cono amortiguación post. 100 mm - largo 200 mm											
V	Cono amortiguación post. 50 mm - largo 100 mm											

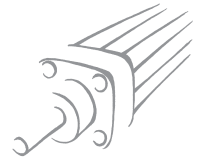

# ACCESORIOS: FIJACIONES

## CHARNELA INTERMEDIA - MOD. EN

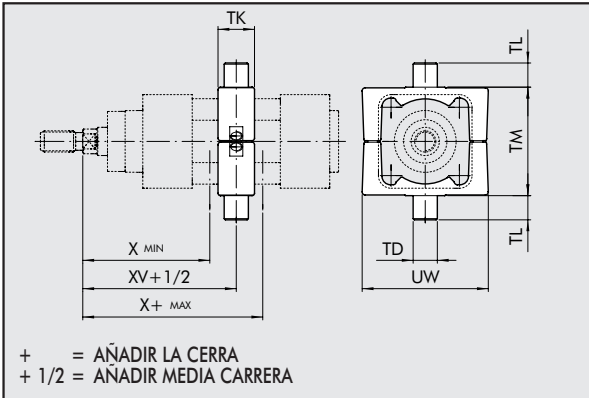

Códigos	Ø	X <sub>(min)</sub>	XV	X <sub>(max)</sub>	TM	TL	TD <sub>3 e 9</sub>	TK	UW	Peso [g]
0950322007	32	63	73	83	50	12	12	22	65	282
0950402007	40	72	82.5	93	63	16	16	28	75	582
0950502007	50	83	90	97	75	16	16	32	95	880
0950632007	63	86.5	97.5	108.5	90	20	20	35	105	1230
0950802007	80	104	110	116	110	20	20	40	130	2030
0951002007	100	113.5	120	126.5	132	25	25	45	145	2600
0951252007	125	135	145	155	160	25	25	50	175	3900

NOTA: servida completa de n. 4 tornillos, n. 2 ejes

## CONTRACHARNELA PARA MOD. EN - MOD. EL

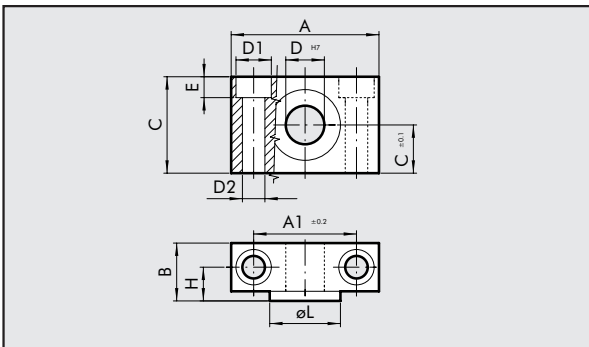

Códigos	Ø	A	A <sub>1</sub>	B	C	C <sub>1</sub>	D <sub>1</sub>	D <sub>2</sub>	D	E	H	ØL	Peso [g]
W0950322009	32	46	32	18	30	15	11	7	12	6.5	10.5	22	162
W0950402009	40	55	36	21	36	18	15	9	16	8.5	12	28	278
W0950402009	50	55	36	21	36	18	15	9	16	8.5	12	28	278
W0950632009	63	65	42	23	40	20	18	11	20	10.5	13	35	414
W0950632009	80	65	42	23	40	20	18	11	20	10.5	13	35	414
W0951002009	100	75	50	28.5	50	25	20	13	25	12.5	16	40	715
W0951002009	125	75	50	28.5	50	25	20	13	25	12.5	16	40	715

NOTA: servida completa de n. 4 tornillos

## PLACA CILINDROS - VÁLVULA SERIE KCV

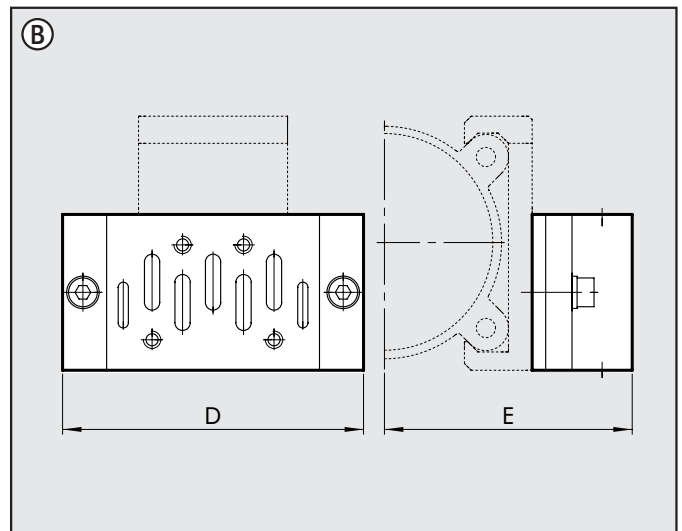
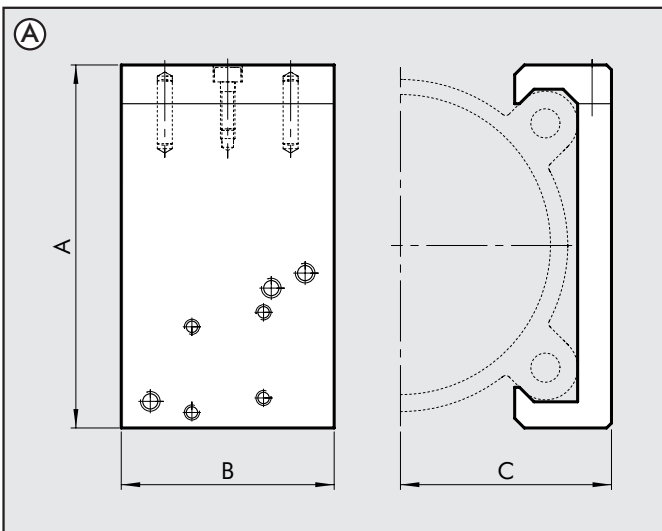

## PLACA FIJACIÓN VÁLVULA - CILINDRO (Fig. A)

Códigos	Ø	A	B	C	ISO 1		ISO 2		Válvulas aplicables	Peso [g]
					D	E	D	E		
0950322090	Ø 32	54	40	29.5	110	64.5	124	70.5	MACH 16 Serie 70 1/8-1/4 ISO 1 - ISO 2	80
0950402090	Ø 40	59.5	40	32.2	110	67.2	124	73.2	MACH 16 Serie 70 1/8-1/4 ISO 1 - ISO 2	86
0950502090	Ø 50	71.5	40	37	110	72	124	78	MACH 16 Serie 70 1/8-1/4 ISO 1 - ISO 2	93
0950632090	Ø 63	81.5	40	42	110	77	124	83	MACH 16 Serie 70 1/8-1/4 ISO 1 - ISO 2	101
0950802090	Ø 80	99	60	53.5	110	88.5	124	94.5	Serie 70 1/8-1/4-1/2 ISO 1 - ISO 2	222
0951002090	Ø 100	119.5	60	63.5	110	98.5	124	104.5	Serie 70 1/8-1/4-1/2 ISO 1 - ISO 2	258
0951252090	Ø 125	148	60	76.5	110	111.5	124	117.9	Serie 70 1/8-1/4-1/2 ISO 1 - ISO 2	298

### KIT FIJACIÓN VÁLVULA SOBRE PLACA

Códigos	KIT para válvula	Composición	Peso [g]
0950002003	MACH 16	Nº 2 TORNILLOS TCE M3x25 con ARANDELA	4
0950002004	Serie 70 1/8-1/4	Nº 2 TORNILLOS TCE M4x30 con ARANDELA	8
0950002006	Serie 70 1/2	Nº 2 TORNILLOS TCE M5x50 con ARANDELA	20
0950002001	ISO 1	ADAPTADOR + BASE SIDE ISO 1 + TORNILLOS + ARANDELA (Fig. B)	230
0950002002	ISO 2	ADAPTADOR + BASE SIDE ISO 2 + TORNILLOS + ARANDELA (Fig. B)	350

### ESQUEMA DE MONTAJE VÁLVULA SOBRE CILINDRO

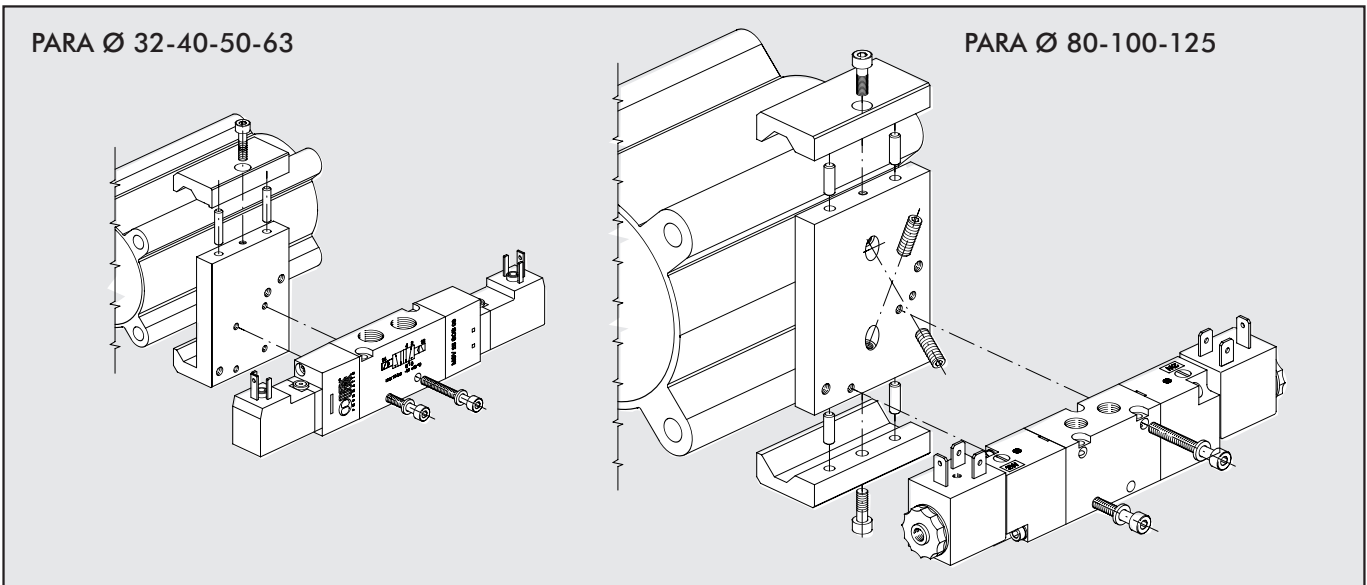

## ACCESORIOS: SENSORES MAGNÉTICOS

### CÓDIGOS DE PEDIDO

Código	Referencia
W0950000201	ACC. SENSOR REED DSM2-C525 HS
W0950000222	ACC. SENSOR E. HALL PNP DSM3-N225
W0950000232	ACC. SENSOR E. HALL NPN DSM3-M225

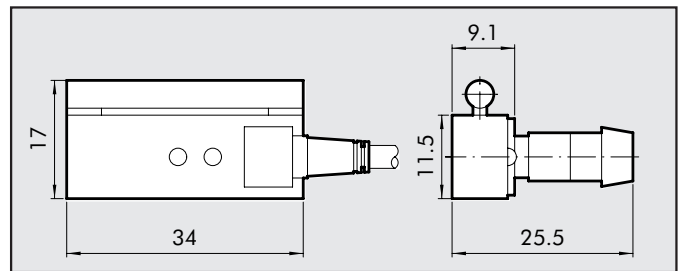

### PLACAS PORTASENORES

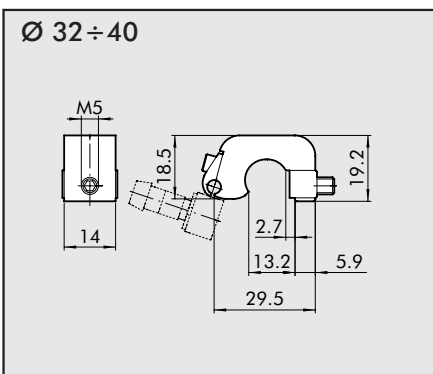

Código W0950000711 Referencia ACC. PLACA D.32-40 DST 80

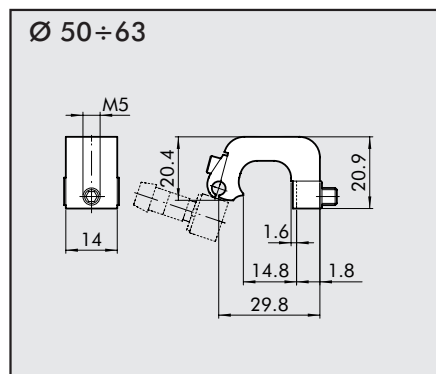

Código W0950000712 Referencia ACC. PLACA D.50-63 DST 81

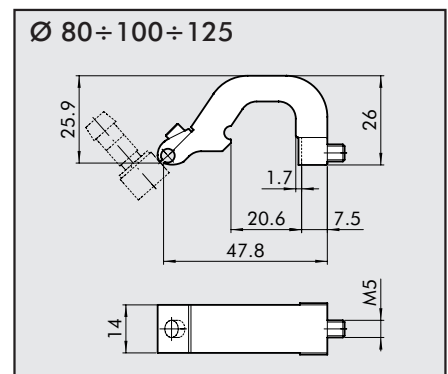

Código W0950000713 Referencia ACC. PLACA D.80-100-125 DST 82



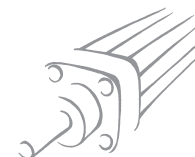

**DATOS TÉCNICOS**

Tipo		REED + VARISTORE + LED 2 hilos	VERSION HALL PNP/NPN 3 HILOS
Contacto		REED + VARISTORE + LED N.O.	EFEECTO HALL NO PNP/NPN
Tensión en AC/DC max	V	3 ÷ 48 V(DC); 3 ÷ 220 (AC)	6-24 V DC
Corriente max. a 25°	mA	500	250
Potencia con carga inductiva	VA	10	-
Potencia con carga resistiva	Watt	50	6
Tiempo de inserción	m sec	1.2	0.8
Tiempo de desinserción	m sec	0.1	3
Punto de inserción	Gauss	110	15
Punto de desinserción	Gauss	95	8
Vida eléctrica	-	10 <sup>7</sup> impulsos	10 <sup>9</sup> impulsos
Resistencia de contacto		0.1	-
Longitud cable	m	2.5	2.5
Sección cable	mm <sup>2</sup>	0.35	0.35
Material cable		PVC blando	PVC blando
Circuito		<p><b>DC</b></p> <p><b>AC</b></p>	<p><b>Version NPN</b></p> <p><b>Version PNP</b></p>

**ADAPTATOR**

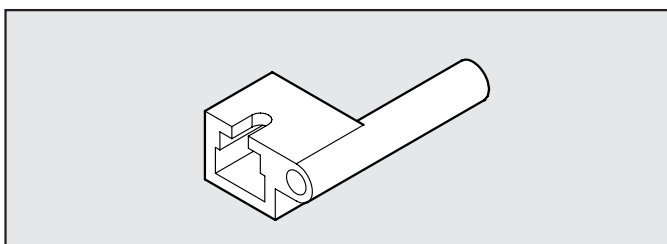

Código	Descripción
W0950001001	Adaptator DSS005 para soporte DST / ST

**MONTAJE**

- ① Cilindro con camisa tradicional
- ② Soporte mod. DST (Ø32 ÷ 125) y ST (Ø160 e 200)
- ③ Adaptador
- ④ Sensore rasante con introduccion vertical
- ⑤ Sensore rasante

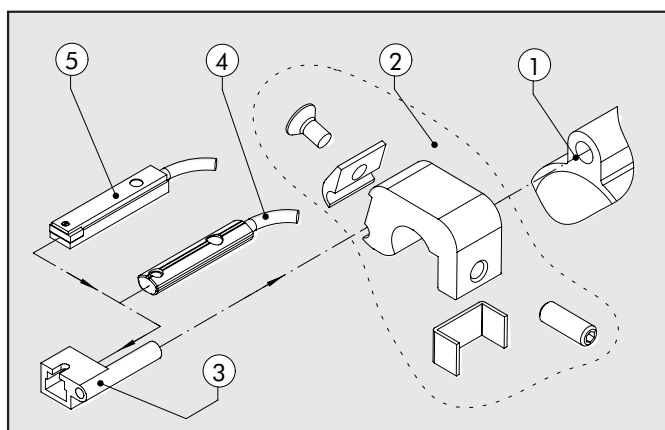

# ACCESORIOS ISO 15552 STD Y TIPO "A" SENSOR INTEGRADO BLOQUEO MECANICO DE VÁSTAGO

Presión de pilotaje	Pp	4÷8 bar (0,4÷0,8 MPa)
Temperatura ambiente	Te	Max 80°C (176°F)
Temperatura fluido	tg	Max 70°C (154°F)
Funcionamiento		Nc-bidireccional
Mecanica		Doble tenaza con bloqueo retorno por contrarresorte
Fuerza de sujeción	F	Ø32 Ø40 Ø50 Ø63 Ø80 Ø100 Ø125
	(N)	650 1100 1600 2500 4000 6300 8700
Mat. cuerpo		Aluminio
Mat. mordaza		Latón
Mat. resorte		Acero
Mat. pistón		Mat. sintético adicionado a Teflón
Mat. juntas		PDF
Conexión pilotaje		1/8"

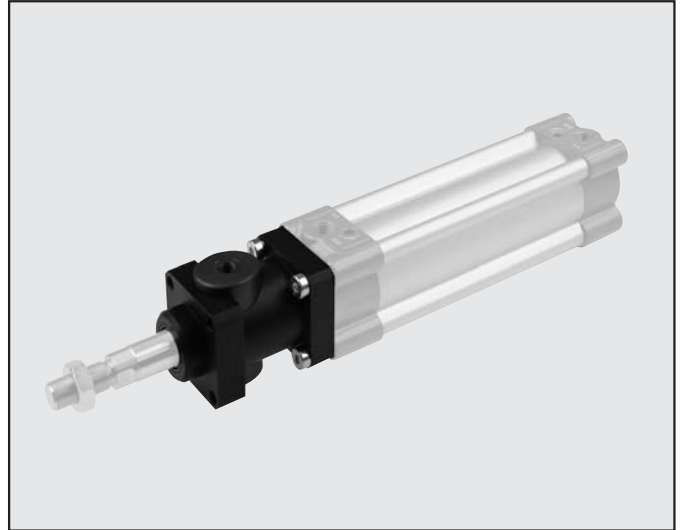

## PRINCIPIO DE FUNCIONAMIENTO

El bloqueo mecánico de vástago es un mecanismo de tipo normalmente cerrado; en ausencia de pilotaje neumático, las dos mordazas bloquean entre las dos los sentidos del vástago del cilindro (Fig. 1) al llegar el pilotaje neumático, el pistón-guía aprieta las dos mordazas al acercarse, venciendo la fuerza del contrarresorte y haciendo posible el deslizamiento de la varilla (Fig. 2).  
Es importante recordar que el funcionamiento del bloqueo mecánico de vástago es de tipo estático: es por tanto necesario bloquear neumáticamente el vástago del cilindro antes de realizar el bloqueo mecánico.

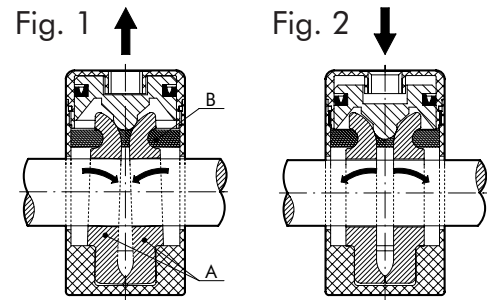

## DIMENSIONES

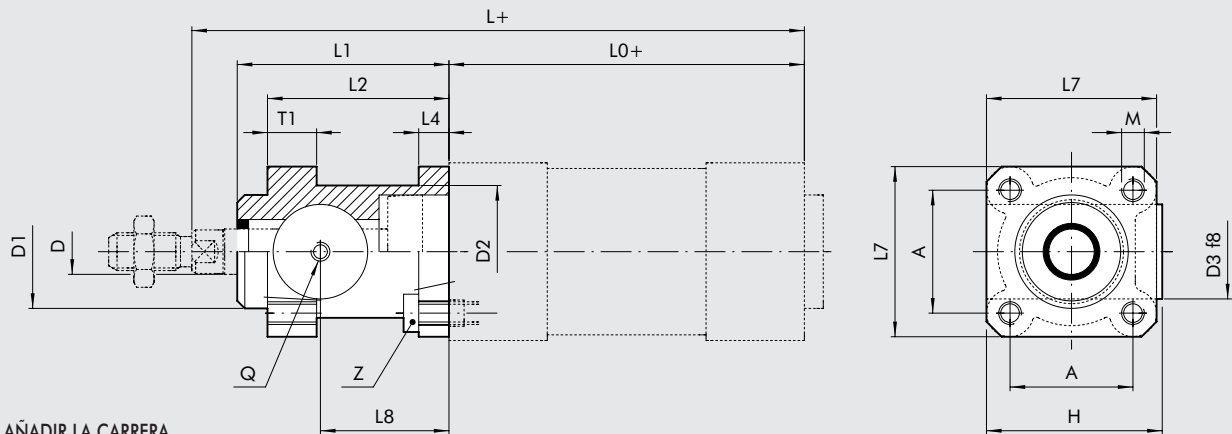

Códigos	Ø	L <sub>1</sub>	L <sub>2</sub>	L <sub>4</sub>	L <sub>7</sub>	L <sub>8</sub>	D	D <sub>1</sub>	D <sub>2</sub>	D <sub>3</sub>	H	A	T <sub>1</sub>	M	Z	Q	L <sub>0</sub>	L	Peso [g]
W5010001102	32	58	48	8	45	34	12	30	35	25	46.5	32.5	13	M6	M6x20	M5	94	162	150
W5010001103	40	65	55	8	50	38	16	35	40	28	53	38	13	M6	M6x20	G1/8	105	180	200
W5010001104	50	82	70	15	60	48	20	40	50	35	64	46.5	16	M8	M8x30	G1/8	106	200	500
W5010001109	63	82	70	15	70	49.5	20	45	60	38	75	56.5	16	M8	M8x30	G1/8	121	215	700
W5010001106	80	110	90	18	90	61	25	45	80	48	95	72	20	M10	M10x35	G1/8	128	251	1700
W5010001107	100	115	100	18	105	68	25	55	100	58	110.5	89	20	M10	M10x35	G1/8	138	266	2700
W5010001108	125	167	122	22	140	86.5	32	60	130	65	150	110	30	M12	M12x40	G1/8	160	347	5600

# ACCESORIOS ISO 1552 STD Y TIPO "A", SENSOR INTEGRADO: FIJACIONES

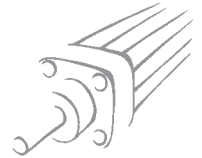

1

## PATAS - MOD. A

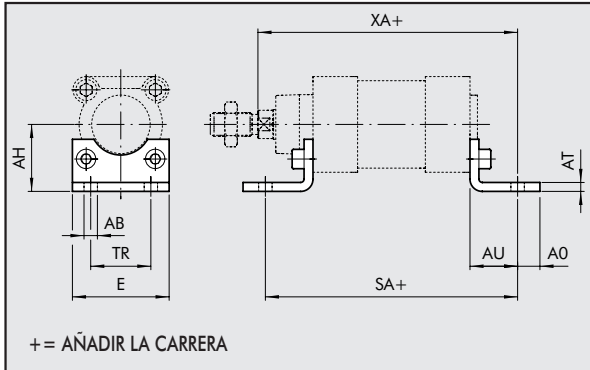

Códigos	Ø	Ø AB	AH	AO	AT	AU	TR	E	XA	SA	Peso [g]
W0950322001	32	7	32	11	4	24	32	45	144	142	76
W0950402001	40	9	36	15	4	28	36	52	163	161	100
W0950502001	50	9	45	15	4	32	45	65	175	170	162
W0950632001	63	9	50	15	6	32	50	75	190	185	266
W0950802001	80	12	63	20	6	41	63	95	215	210	456
W0951002001	100	14	71	25	6	41	75	115	230	220	572
W0951252001	125	16	90	15	7	45	90	140	270	250	1130

Nota: n. 1 pieza por confección completa de n. 2 tornillos

## CHARNELA HEMBRA - MOD. B

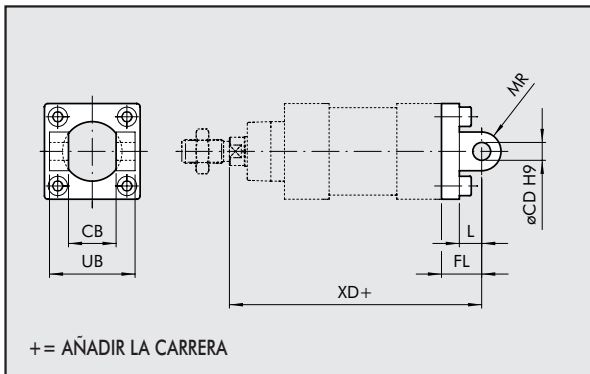

Códigos	Ø	UB	CB	FL	ØCD	XD	MR	L	Peso [g]
W0950322003	32	45	26	22	10	142	10	10	116
W0950402003	40	52	28	25	12	160	12	10	160
W0950502003	50	60	32	27	12	170	12	12	252
W0950632003	63	70	40	32	16	190	16	12	394
W0950802003	80	90	50	36	16	210	16	16	670
W0951002003	100	110	60	41	20	230	20	16	1085
W0951252003	125	130	70	50	25	275	25	20	2000

Nota: servida completa de n. 4 tornillos, n. 4 arandela, n. 2 seeger, n. 1 pasador

## CHARNELA MACHO - MOD. BA

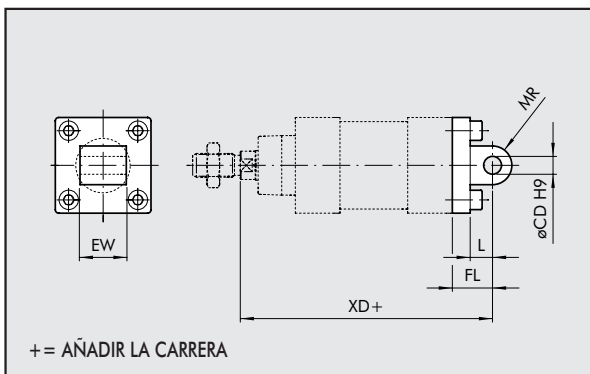

Códigos	Ø	EW	FL	MR	Ø CD	L	XD	Peso [g]
W0950322004	32	26	22	11	10	12	142	94
W0950402004	40	28	25	13	12	15	160	124
W0950502004	50	32	27	13	12	15	170	220
W0950632004	63	40	32	17	16	20	190	316
W0950802004	80	50	36	17	16	20	210	578
W0951002004	100	60	41	21	20	25	230	850
W0951252004	125	70	50	26	25	30	275	1590

Nota: servida completa de n. 4 tornillos, n. 4 arandela

## CHARNELA MACHO CON ROTULA - MOD. BAS

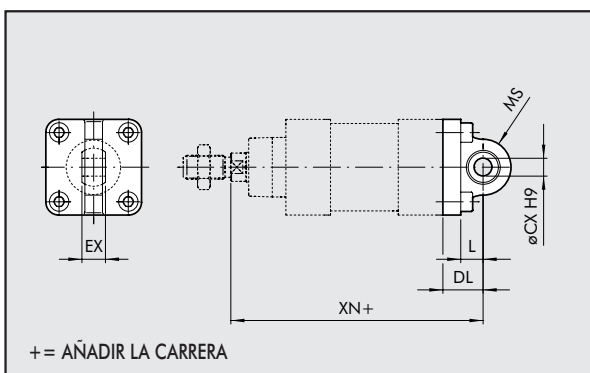

Códigos	Ø cil.	DL	MS	L	XN	CX	EX	Peso [g]
W0950322006	32	22	16	12	142	10	14	106
W0950402006	40	25	19	15	160	12	16	142
W0950502006	50	27	19	15	170	12	16	236
W0950632006	63	32	24	20	190	16	21	336
W0950802006	80	36	24	20	210	16	21	572
W0951002006	100	41	30	25	230	20	25	840
W0951252006	125	50	36	30	275	25	31	1520

Nota: servida completa de n. 4 tornillos, n. 4 arandela

**CONTRACHARNELA "CETOP"  
PARA MOD. B - MOD. GL**

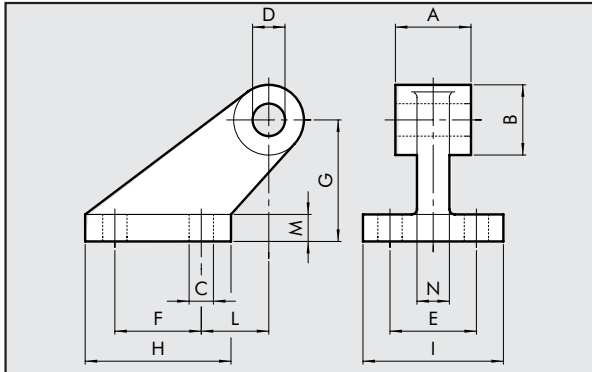

Códigos	Ø	A	B	C	D	E	F	G	H	I	L	M	N	Peso [g]
W0950322008	32	26	19	7	10	25	20	32	37	41	18	8	10	96
W0950402008	40	28	26	9	12	32	32	45	54	52	25	10	12	216
W0950502008	50	32	26	9	12	32	32	45	54	52	25	10	12	212
W0950632008	63	40	33	11	16	40	50	63	75	63	32	12	15	440
W0950802008	80	50	33	11	16	40	50	63	75	63	32	12	15	464
W0951002008	100	60	44	14	20	50	70	90	103	80	40	16	22	985
W0951252008	125	70	44	14	25	50	70	90	103	80	40	16	22	1000

Nota: servida completa de n. 4 tornillos, n. 4 arandela

**CONTRACHARNELA ISO  
PARA MOD. B - MOD. GS**

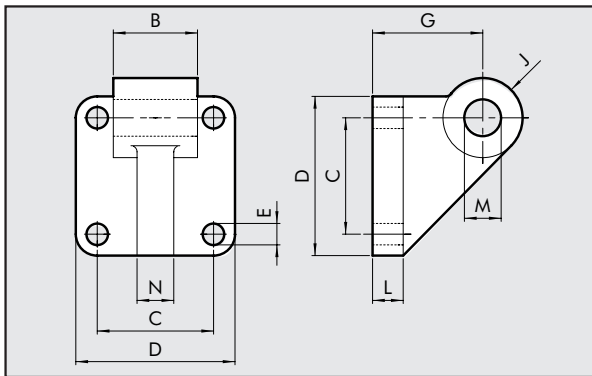

Códigos	Ø	B	C	D	E	G	J	L	M	N	Peso [g]
W0950322108	32	25.5	32.5	45	7	32	11	10	10	10	106
W0950402108	40	27.5	38	52	7	36	13	10	12	12	138
W0950502108	50	31.5	46.5	65	9	45	13	12	12	12	252
W0950632108	63	39.5	56.5	75	9	50	17	12	16	15	350
W0950802108	80	49.5	72	95	11	63	17	16	16	15	655
W0951002108	100	59.5	89	115	11	73	21	16	20	22	980

Nota: servida completa de n. 4 tornillos, n. 4 arandela

**BRIDA ANTERIOR - MOD. C**

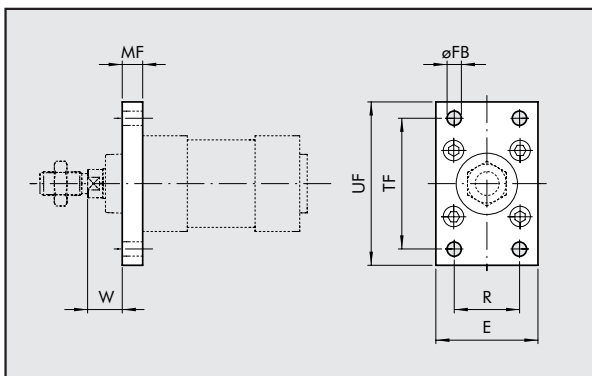

Códigos	Ø	TF	UF	E	MF	R	øFB	W	Peso [g]
W0950322002	32	64	80	50	10	32	7	16	246
W0950402002	40	72	90	55	10	36	9	20	290
W0950502002	50	90	110	65	12	45	9	25	522
W0950632002	63	100	120	75	12	50	9	25	670
W0950802002	80	126	153	95	16	63	12	30	1420
W0951002002	100	150	178	115	16	75	14	35	2040
W0951252002	125	180	220	140	20	90	16	45	4300

Nota: servida completa de n. 4 tornillos

**BRIDA POSTERIOR - MOD. C**

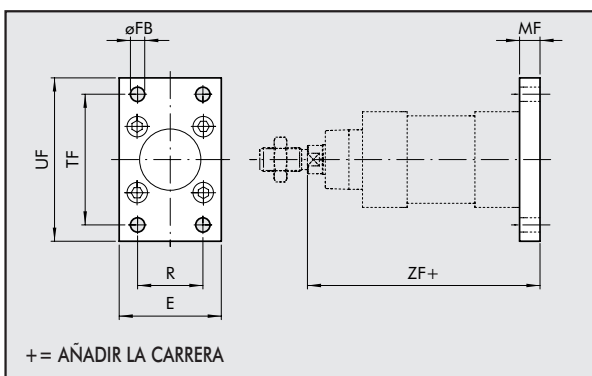

Códigos	Ø	TF	UF	E	MF	R	øFB	ZF	Peso [g]
W0950322002	32	64	80	50	10	32	7	130	246
W0950402002	40	72	90	55	10	36	9	145	290
W0950502002	50	90	110	65	12	45	9	155	522
W0950632002	63	100	120	75	12	50	9	170	670
W0950802002	80	126	153	95	16	63	12	190	1420
W0951002002	100	150	178	115	16	75	14	205	2040
W0951252002	125	180	220	140	20	90	16	245	4300

Nota: servida completa de n. 4 tornillos

+ = AÑADIR LA CARRERA



**TUERCA PARA VÁSTAGO - MOD. S**

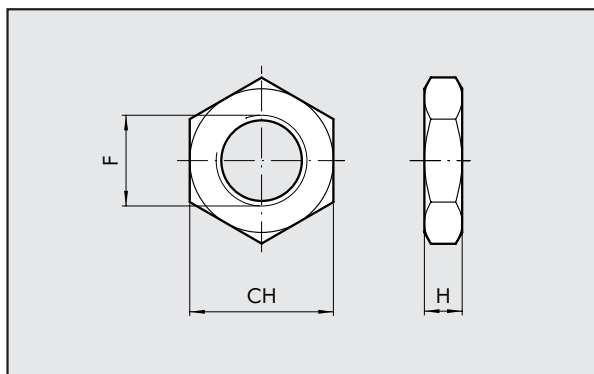

Códigos	Ø	F	H	CH	Peso [g]
0950322010	32	M10x1.25	6	17	6
0950402010	40	M12x1.25	7	19	12
0950502010	50/63	M16x1.5	8	24	20
0950802010	80/100	M20x1.5	9	30	32
0951252010	125	M27x2	12	41	74

Nota: n. 1 pieza por confección

**HORQUILLA MOD. GK-M**

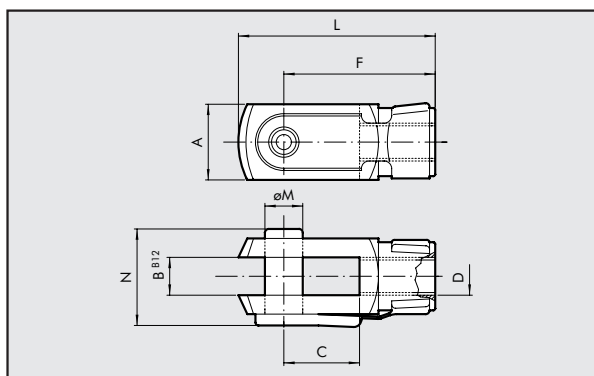

Códigos	Ø	Ø M	C	B	A	L	F	D	N	Peso [g]
W0950322020	32	10	20	10	20	52	40	M10x1.25	26	92
W0950402020	40	12	24	12	24	62	48	M12x1.25	32	148
W0950502020	50	16	32	16	32	83	64	M16x1.5	40	340
W0950502020	63	16	32	16	32	83	64	M16x1.5	40	340
W0950802020	80	20	40	20	40	105	80	M20x1.5	40	690
W0950802020	100	20	40	20	40	105	80	M20x1.5	48	690
W0951252020	125	30	54	30	55	148	110	M27x2	65	1835

Nota: n. 1 pieza por confección

**ROTULA - MOD. GA-M**

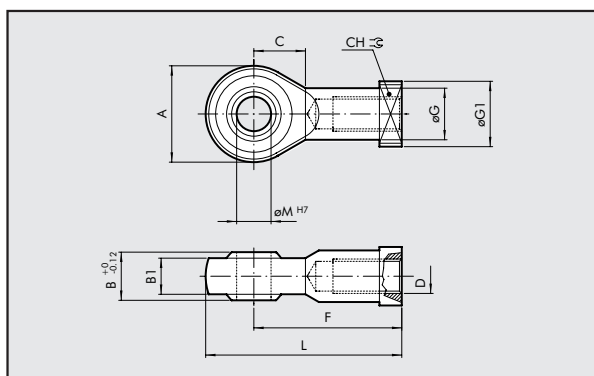

Códigos	Ø	Ø M	C	B1	B	A	L	F	D	Ø G	CH	Ø G1	Peso [g]
W0950322025	32	10	15	10.5	14	28	57	43	M10x1.25	15	17	19	78
W0950402025	40	12	17	12	16	32	66	50	M12x1.25	17.5	19	19	116
W0950502025	50	16	22	15	21	42	85	64	M16x1.5	22	22	22	226
W0950502025	63	16	22	15	21	42	85	64	M16x1.5	22	22	22	226
W0950802025	80	20	26	18	25	50	102	77	M20x1.5	27.5	30	27	404
W0950802025	100	20	26	18	25	50	102	77	M20x1.5	27.5	30	27	404
W0951252025	125	30	36	25	37	70	145	110	M27x2	40	41	50	1190

Nota: n. 1 pieza por confección

**ROTULA AUTOALINEANTE - MOD. GA-K**

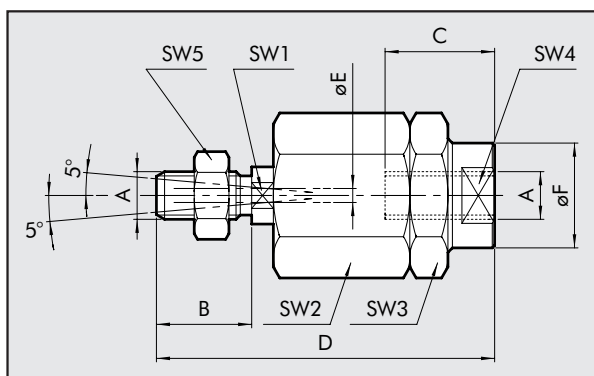

Códigos	Ø	A	B	C	D	Ø F	Ø E	SW <sub>1</sub>	SW <sub>2</sub>	SW <sub>3</sub>	SW <sub>4</sub>	SW <sub>5</sub>	Peso [g]
W0950322030	32	M10x1.25	20	20	71	22	4	12	30	30	19	17	216
W0950402030	40	M12x1.25	24	20	75	22	4	12	30	30	19	19	220
W0950502030	50	M16x1.5	32	32	103	32	4	20	41	41	30	24	620
W0950502030	63	M16x1.5	32	32	103	32	4	20	41	41	30	24	620
W0950802030	80	M20x1.5	40	40	119	32	4	20	41	41	30	30	680
W0950802030	100	M20x1.5	40	40	119	32	4	20	41	41	30	30	680

Nota: n. 1 pieza por confección

# CILINDRO ISO 1552 STD Y TIPO "A" SENSOR INTEGRADO: RECAMBIOS

## NEW RELEASE

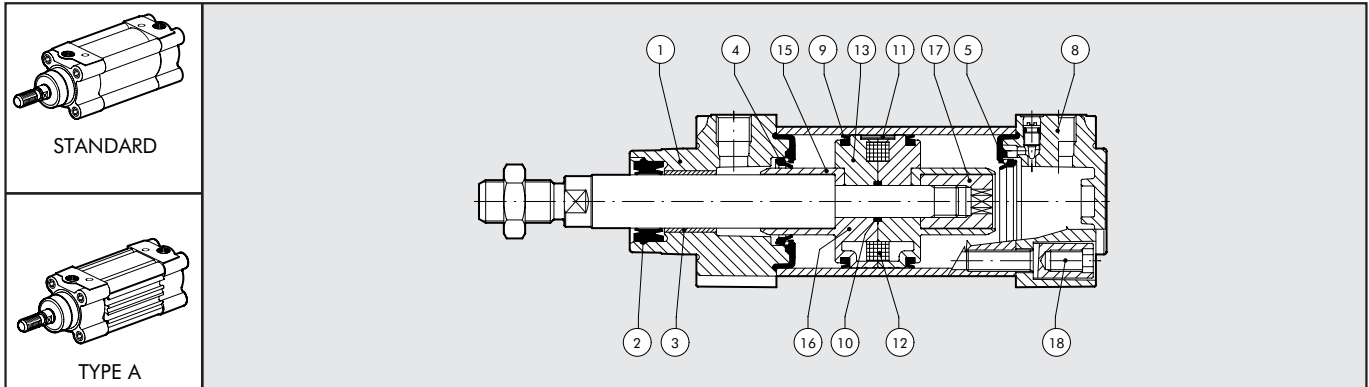

Tipología	Piezas	Diámetro	Código
Kit completo juntas poliuretano	2-4-5-9-10	Ø 32÷125	009 ... 0101
Kit completo juntas NBR	2-4-5-9-10	Ø 32÷125	009 ... 0502
Kit culata ant. compl. poliuretano	1-2-3-4-5-17-18	Ø 32÷125	009 ... 0110N
Kit culata ant. compl. NBR	1-2-3-4-5-17-18	Ø 32÷125	009 ... 0304N
Kit culata pst. compl. poliuretano	4-5-8-17-18	Ø 32÷125	009 ... 0111N
Kit culata pst. compl. NBR	4-5-8-17-18	Ø 32÷125	009 ... 0305N
Kit pistón completo poliuretano	9-10-16-19	Ø 32÷63	009 ... 0604
Kit pistón completo poliuretano	9-10-11-13-15-18	Ø 80÷125	009 ... 0604
Kit pistón completo NBR	9-10-16-19	Ø 32÷63	009 ... 0602
Kit pistón completo NBR	9-10-11-13-15-18	Ø 80÷125	009 ... 0602
Kit culata A + P + pistón compl. poliuretano	1-2-3-4-5-8-9-10-16-17-18	Ø 32÷63	009 ... 0704N
Kit culata A + P + pistón compl. poliuretano	1-2-3-4-5-8-9-10-11-13-15-17-18	Ø 80÷125	009 ... 0704N
Kit culata A + P + pistón compl. NBR	1-2-3-4-5-8-9-10-16-17-18	Ø 32÷63	009 ... 0702N
Kit culata A + P + pistón compl. NBR	1-2-3-4-5-8-9-10-11-13-15-17-18	Ø 80÷125	009 ... 0702N
Imanes	12	Ø 32÷125	009 ... 0800

## OLD RELEASE

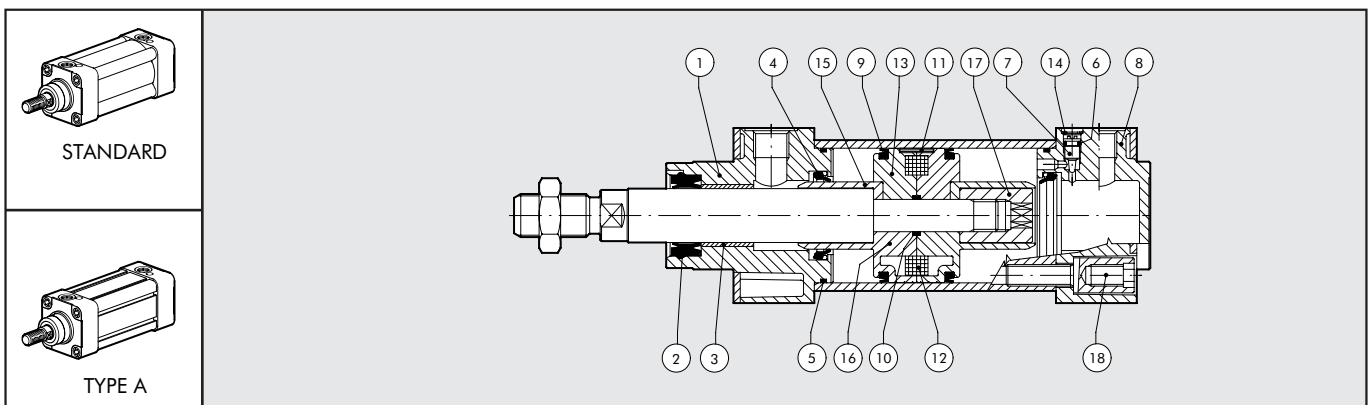

Tipología	Piezas	Diámetro	Código
Kit completo juntas poliuretano	2-4-5-6-9-10	Ø 32÷125	009 ... 0101
Kit completo juntas NBR	2-4-5-6-9-10	Ø 32÷125	009 ... 0502
Kit culata ant. compl. poliuretano	1-2-3-4-5-6-7-14-17-18	Ø 32÷125	009 ... 0110
Kit culata ant. compl. NBR	1-2-3-4-5-6-7-14-17-18	Ø 32÷125	009 ... 0304
Kit culata pst. compl. poliuretano	4-5-6-7-8-14-17-18	Ø 32÷125	009 ... 0111
Kit culata pst. compl. NBR	4-5-6-7-8-14-17-18	Ø 32÷125	009 ... 0305
Kit pistón completo poliuretano	9-10-16-19	Ø 32÷63	009 ... 0604
Kit pistón completo poliuretano	9-10-11-13-15-18	Ø 80÷125	009 ... 0604
Kit pistón completo NBR	9-10-16-19	Ø 32÷63	009 ... 0602
Kit pistón completo NBR	9-10-11-13-15-18	Ø 80÷125	009 ... 0602
Kit culata A + P + pistón compl. poliuretano	1-2-3-4-5-6-7-8-9-10-14-16-17-18	Ø 32÷63	009 ... 0704
Kit culata A + P + pistón compl. poliuretano	1-2-3-4-5-6-7-8-9-10-11-13-14-15-17-18	Ø 80÷125	009 ... 0704
Kit culata A + P + pistón compl. NBR	1-2-3-4-5-6-7-8-9-10-14-16-17-18	Ø 32÷63	009 ... 0702
Kit culata A + P + pistón compl. NBR	1-2-3-4-5-6-7-8-9-10-11-13-14-15-17-18	Ø 80÷125	009 ... 0702
Imanes	12	Ø 32÷125	009 ... 0800



GRAFICO CARGAS UNIDADES DE GUIA

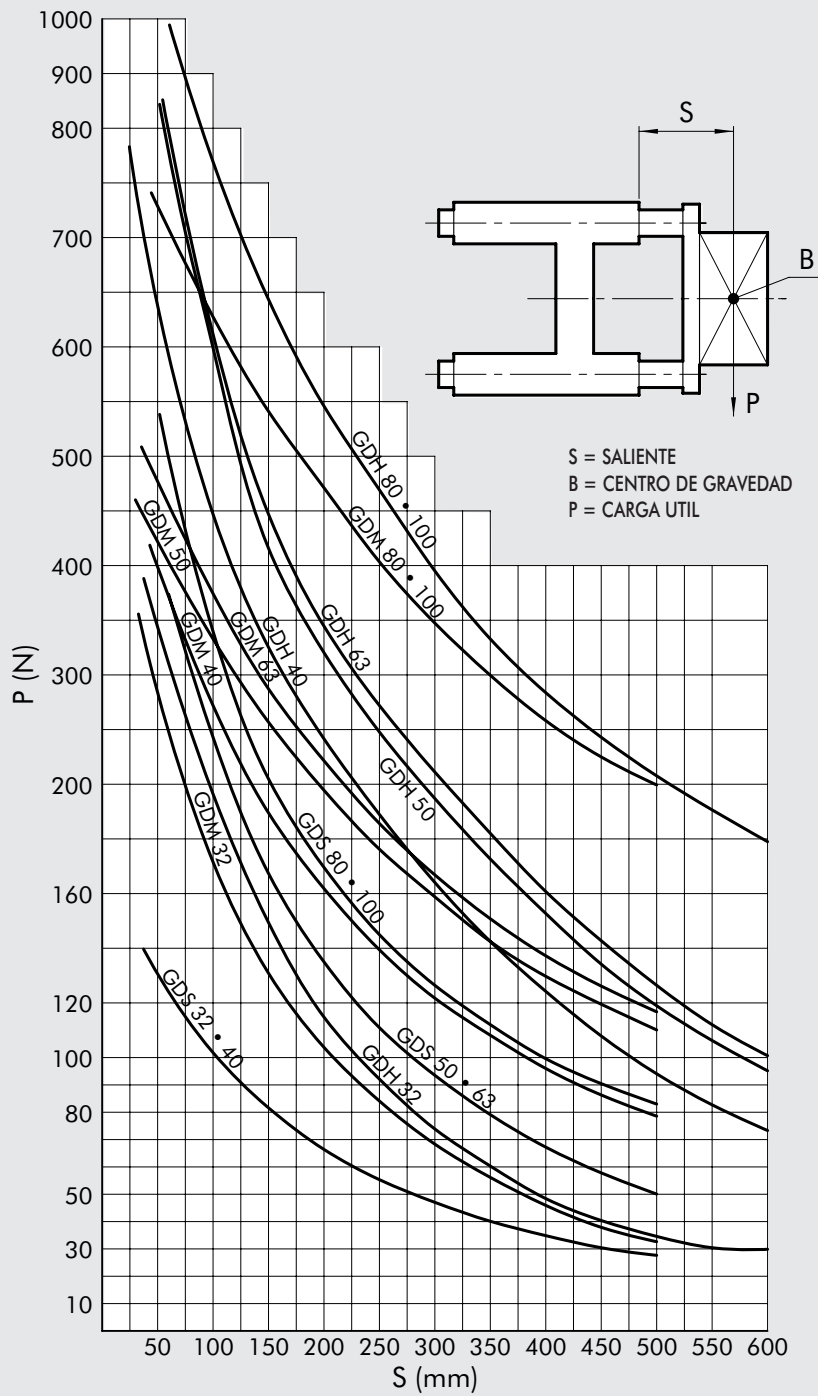



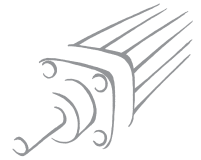

**DIMENSIONES TIPO GDS**

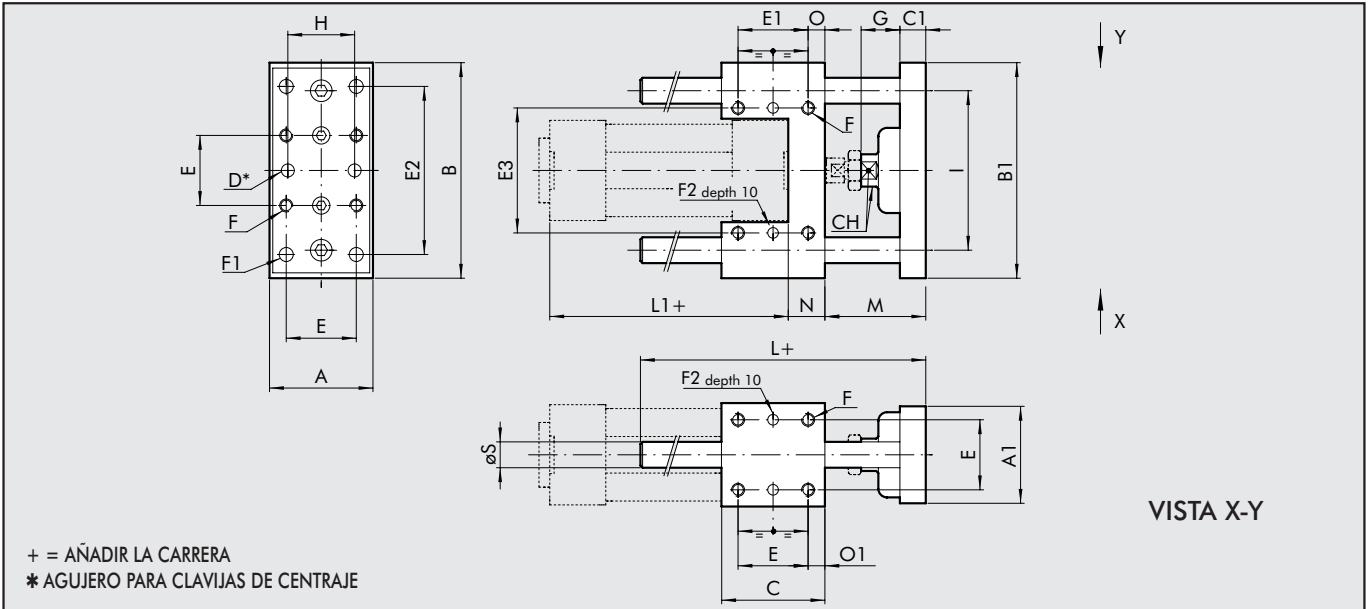

Ø	A	A <sub>1</sub>	B	B <sub>1</sub>	C	C <sub>1</sub>	DH <sup>7</sup>	E	E <sub>1</sub>	E <sub>2</sub>	E <sub>3</sub>	F	F <sub>1</sub>	F <sub>2</sub> <sup>H7</sup>	G	H	I	L	L <sub>1</sub>	M	N	O	O <sub>1</sub>	Ø S	Ch
32	48	45	100	95	48	12	6	32.5	32.5	78	58	M6	6.5	6	18	31	74	108	94	46	17	7.8	7.8	12	15
40	56	53	106	101	58	15	6	38	38	84	64	M6	6.5	6	21	36	80	120	105	52	21	10	10	12	15
50	66	63	125	120	59	15	6	46.5	46.5	100	80	M8	8.5	6	24	45	96	130	106	65	25	6.3	6.3	16	22
63	76	73	132	127	76	15	6	56.5	56.5	105	95	M8	8.5	6	24	45	104	145	121	65	25	9.8	9.8	16	22
80	98	95	165	160	90	16	6	72	50	130	130	M10	11	6	31	56	130	170	128	71	34	20	9	20	27
100	118	115	185	180	110	16	6	89	70	150	150	M10	11	6	31	56	152	190	138	71	39	20	10.5	20	27

**DIMENSIONES TIPO GDH-GDM**

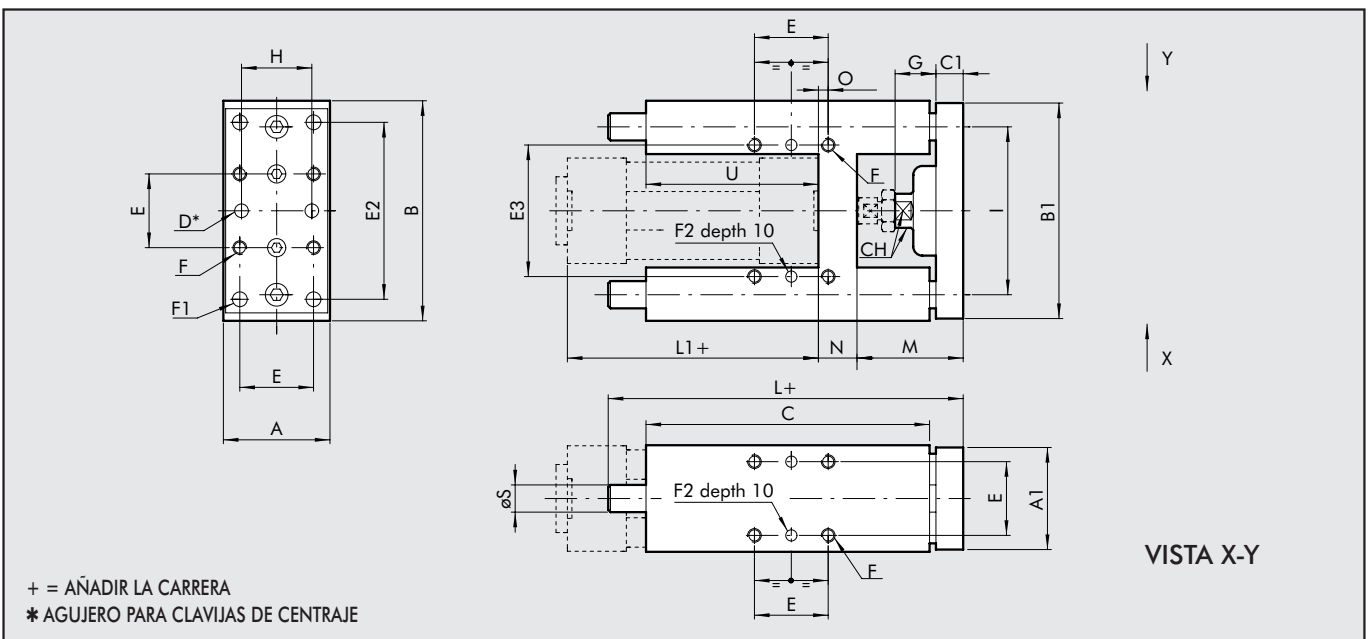

Ø	A	A <sub>1</sub>	B	B <sub>1</sub>	C	C <sub>1</sub>	Ch	DH <sup>7</sup>	E	E <sub>2</sub>	E <sub>3</sub>	F	F <sub>1</sub>	F <sub>2</sub> <sup>H7</sup>	G	H	I	L	L <sub>1</sub>	M	N	O	Ø S	U
32	49	45	97	90	125	12	13	6	32.5	78	61	M6	6.5	6	18	31	74	177	94	47	17	4.3	12	76
40	58	54	115	110	139	15	15	6	38	84	69	M6	6.5	6	21	36	87	192	105	53	21	11	16	81
50	69	63	137	130	148	15	22	6	46.5	100	85	M8	8.5	6	24	45	104	205	106	63	26	18.5	20	78
63	85	79	152	145	182	15	22	6	56.5	105	100	M8	8.5	6	24	45	119	237	121	62	26	15.3	20	111
80	105	99	189	180	215	20	27	6	72	130	130	M10	11	6	31	56	148	280	128	76	34	21	25	128
100	129	120	213	200	220	20	27	6	89	150	150	M10	11	6	31	56	172	280	138	76	39	24.5	25	128

## UNIDADES DE GUIADO - MOD. C

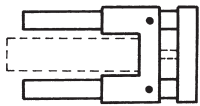
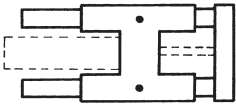
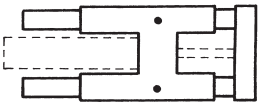
Versión	Calibre	Sigla	Códigos
Deslizamiento sobre casquillos (GDS) 	32	UNIT MW DS 032...	W 0700321...
	40	UNIT MW DS 040...	W 0700401...
	50	UNIT MW DS 050...	W 0700501...
	63	UNIT MW DS 063...	W 0700631...
	80	UNIT MW DS 080...	W 0700801...
	100	UNIT MW DS 100...	W 0701001...
Deslizamiento sobre casquillos (GDH) 	32	UNIT MW DH 032...	W 0700322...
	40	UNIT MW DH 040...	W 0700402...
	50	UNIT MW DH 050...	W 0700502...
	63	UNIT MW DH 063...	W 0700632...
	80	UNIT MW DH 080...	W 0700802...
	100	UNIT MW DH 100...	W 0701002...
Deslizamiento sobre cojinetes (GDM) 	32	UNIT MW DM 032...	W 0700323...
	40	UNIT MW DM 040...	W 0700403...
	50	UNIT MW DM 050...	W 0700503...
	63	UNIT MW DM 063...	W 0700633...
	80	UNIT MW DM 080...	W 0700803...
	100	UNIT MW DM 100...	W 0701003...

**Nota:** para completar la referencia y el código, añadir la carrera en 3 cifras; (ejemplo: 50=050).

## DIMENSIONES VERSIÓN BLOQUEO VÁSTAGO + UNIDAD DE GUIA

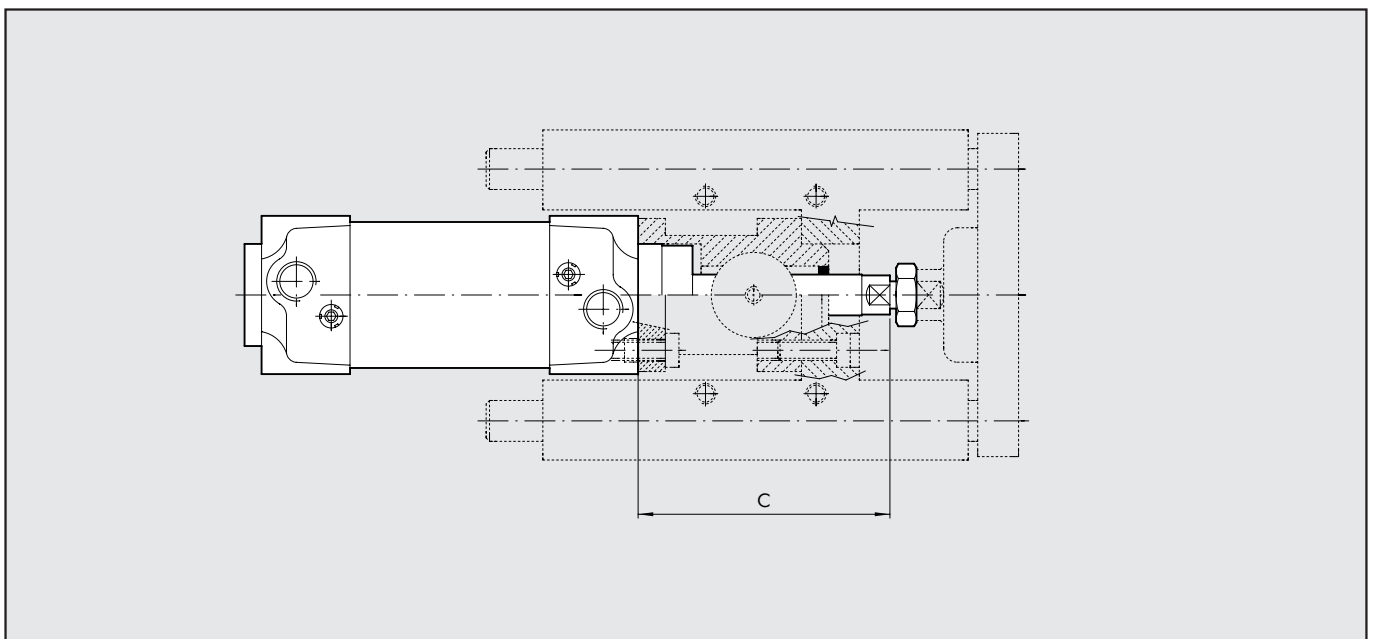

Ø	C
32	74
40	85
50	108
63	107
80	136
100	143
126	187