

CILINDRO COMPACTO GUIADO SERIE CMPG Ø 16÷100

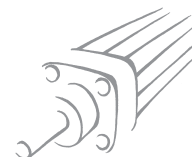

1

El cilindro compacto guiado serie CMPG representa una robusta y practica solución de cilindro con unidad de guía integrada. En la camisa en barra de aluminio anodizado están directamente montados los casquillos de guiado de las columnas. Se puede escoger entre dos soluciones de casquillos de guía: casquillos de bronce sinterizado aparejadas con columnas en acero al carbono cromado y rectificado, o guías a recirculación de bolas aparejadas con columnas en acero templado, cromado y rectificado.

En un lado del cuerpo están las ranuras para alojar los sensores del tipo rasante.

Existe la versión no amortiguada, en la que el golpe de final de carrera está silenciado por juntas frontales en NBR, o la versión amortiguada, con tornillos regulables para graduar la amortiguación.

Por la fijación hay agujeros roscados y agujeros calibrados para orificios de referencia.

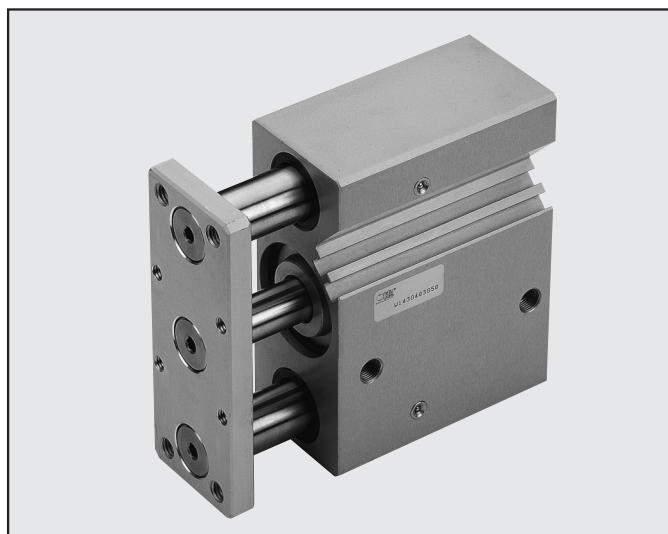

DATOS TÉCNICOS		AMORTIGUADO	NO AMORTIGUADO
Presión de trabajo	bar	1 ÷ 10	
	MPa	0.1 ÷ 1	
Temperatura de trabajo	psi	14.5 ÷ 145	
	°C	0 ÷ 80°C	
Temperatura con aire seco	°F	32 ÷ 176°F	
	°C	-20°	
Diámetros	mm	Ø16; 20; 25; 32; 40; 50; 63.	Ø16; 20; 25; 32; 40; 50; 63; 80; 100.
	mm	Ø16: 20-30-40-50 Ø20; Ø25: 20-30-40-50-75-100-150 Ø32÷Ø63: 25-50-75-100-150-175	Ø16: 10-20-25*-30-40-50-75-100-150-200 Ø20; Ø25: 20-25*-30-40-50-75-100-150 Ø32÷Ø100: 25-50-75-100-150-200
Versión		Con casquillo de bronce Von rodamiento de bolas	
Peso		Ver DATOS TECNICOS GENERALES PAG. 1.1/07 * Solo para version con casquillo de bronce	

COMPONENTES

- ① CAMISA: aluminio anodizado
- ② VÁSTAGO: acero cromado y rectificado
- ③ VÁSTAGO DE GUIA: acero cromado y rectificado
- ④ VÁSTAGO DE GUIA: acero al cromo templado y cromado
- ⑤ CASQUILLO POSTERIOR: aluminio anodizado
- ⑥ CASQUILLO ANTERIOR: aluminio anodizado
- ⑦ CASQUILLO DE GUIA: bronce autolubrificante
- ⑧ JUNTA AMORTIGUACIÓN: NBR
- ⑨ PISTON: aluminio
- ⑩ MAGNETO: plastoferrita
- ⑪ JUNTAS PISTON: NBR (PARKER PRADIFA)
- ⑫ ANILLO DE GUIA: PTFE
- ⑬ CASQUILLO GUIA: bronce autolubrificante
- ⑭ RODAMIENTO DE BOLAS
- ⑮ JUNTAS RASCADORAS: NBR o FKM/FPM
- ⑯ ENGRASADORES: acero cincado y inox

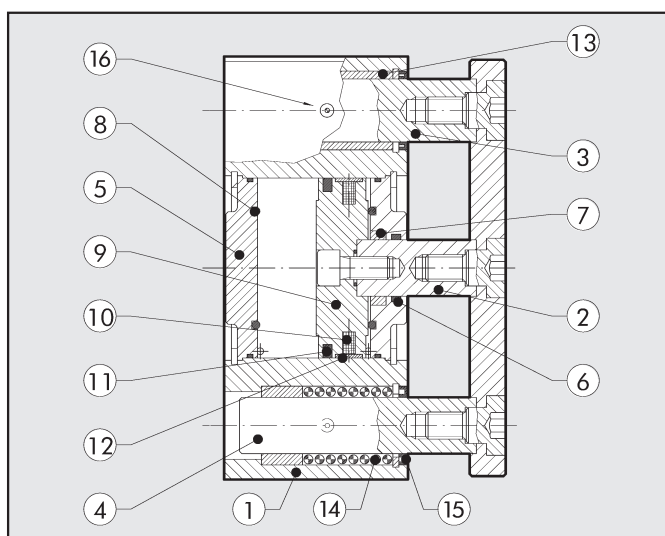

CARGA LATERAL MÁXIMA ADMISIBLE

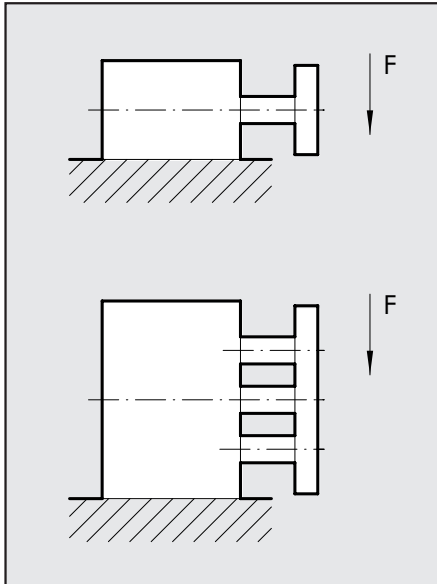

Ø mm	Guía	Carrera (mm)										
		10	20	25	30	40	50	75	100	150	175	200
16	Bronce	35	29	27	26	23	20	16	14	10	-	8
	Rod. bolas	29	31	-	27	38	34	29	24	12	-	8
20	Bronce	-	52	50	45	39	35	58	49	38	-	31
	Rod. bolas	-	56	-	48	79	70	54	50	27	-	32
25	Bronce	-	71	67	61	54	48	78	66	50	-	41
	Rod. bolas	-	72	-	62	78	73	60	52	37	-	30
32	Bronce	-	-	197	-	-	168	138	109	78	70	65
	Rod. bolas	-	-	89	-	-	60	276	217	138	122	110
40	Bronce	-	-	197	-	-	168	138	109	78	70	65
	Rod. bolas	-	-	89	-	-	60	276	217	138	122	110
50	Bronce	-	-	295	-	-	256	216	177	125	112	103
	Rod. bolas	-	-	138	-	-	89	393	314	184	163	148
63	Bronce	-	-	295	-	-	256	216	177	125	112	103
	Rod. bolas	-	-	138	-	-	89	393	314	184	163	148
80	Bronce	-	-	354	-	-	305	256	207	153	-	128
	Rod. bolas	-	-	236	-	-	158	864	687	413	-	335
100	Bronce	-	-	540	-	-	471	413	344	254	-	213
	Rod. bolas	-	-	471	-	-	314	1374	1074	629	-	511

N.B.: la fuerza indicada en la tabla esta expresada en N

MOMENTO MÁXIMO ADMISIBLE SOBRE LA PLACA

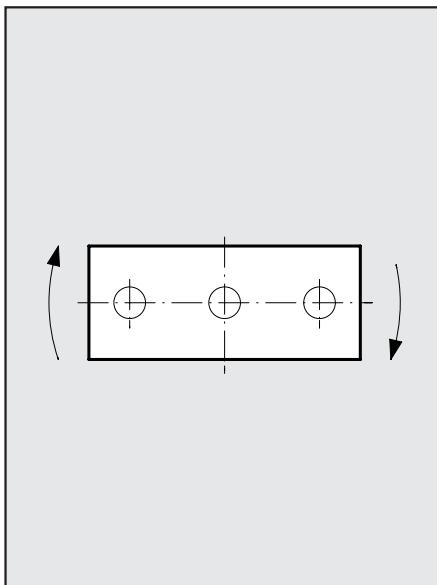

Ø mm	Guía	Carrera (mm)										
		10	20	25	30	40	50	75	100	150	200	
16	Bronce	0.51	0.45	0.40	0.36	0.32	0.28	0.24	0.20	0.46	0.12	
	Rod. bolas	0.74	0.6	-	0.5	0.72	0.65	0.54	0.45	0.35	0.25	
20	Bronce	-	0.92	0.85	0.79	0.72	0.64	1.05	0.9	0.69	0.56	
	Rod. bolas	-	1.28	-	1.08	1.78	1.59	1.24	1	0.61	0.49	
25	Bronce	-	1.55	1.42	1.32	1.18	1.04	1.7	1.44	1.10	0.90	
	Rod. bolas	-	1.98	-	1.7	2.16	2.2	1.66	1.4	1.02	0.82	
32	Bronce	-	-	3.94	-	-	2.95	2.46	1.97	1.55	1.24	
	Rod. bolas	-	-	1.97	-	-	1	2.96	2.44	2.4	2.18	
40	Bronce	-	-	4.4	-	-	3.45	2.96	2.46	1.7	1.4	
	Rod. bolas	-	-	2.46	-	-	1.45	6.38	5.4	3	2.4	
50	Bronce	-	-	7.36	-	-	5.9	4.9	4.4	3	2.5	
	Rod. bolas	-	-	3.45	-	-	2.44	10.8	8.35	4.5	3.6	
63	Bronce	-	-	7.85	-	-	6.38	5.4	4.9	3.4	2.8	
	Rod. bolas	-	-	3.94	-	-	2.46	11.77	9.3	5	4	
80	Bronce	-	-	11.78	-	-	9.8	7.84	6.88	5.3	4.4	
	Rod. bolas	-	-	9.34	-	-	5.88	31.38	24.5	10.4	11.7	
100	Bronce	-	-	22.55	-	-	19.62	16.68	14.7	10.65	8.9	
	Rod. bolas	-	-	21.56	-	-	13.73	63.72	49.1	26.6	21.6	

N.B.: la fuerza indicada en la tabla esta expresada en Nm

POSIBILIDADES DE MONTAJE

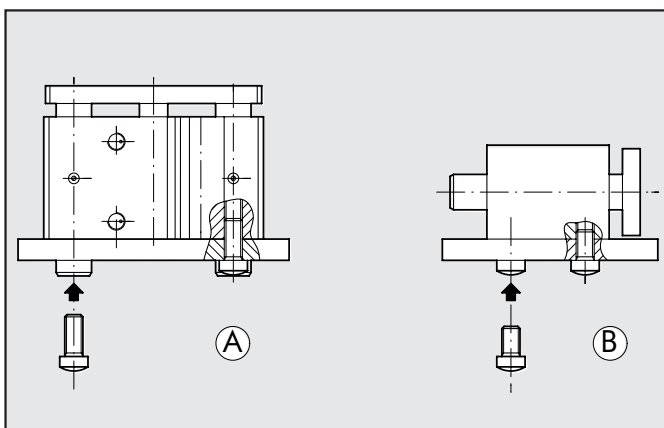

Si el cilindro Compacto Guiado viene montado como en la figura A, es oportuno prever en la estructura, dos orificios pasantes para las columnas de guiado.

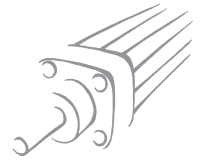

UTILIZACIÓN FUNCIÓN DE TOPE

1

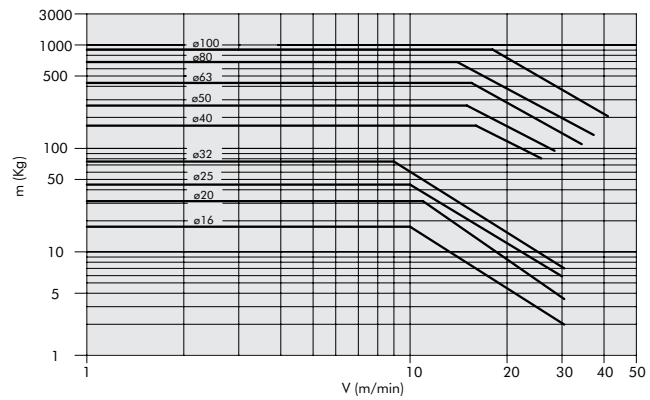
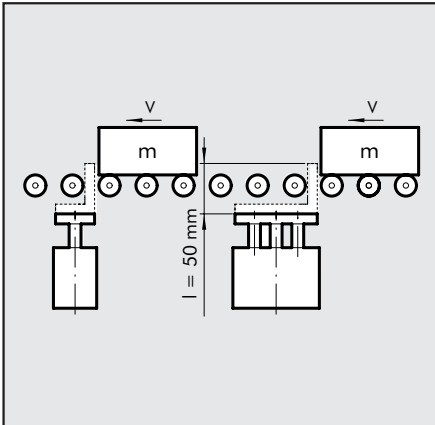

El grafico es referido a un cilindro carrera 50 mm

UTILIZACIÓN FUNCIÓN DE LEVANTAMIENTO

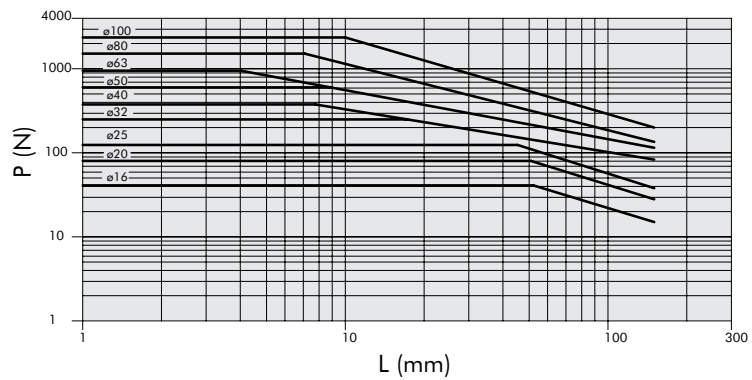
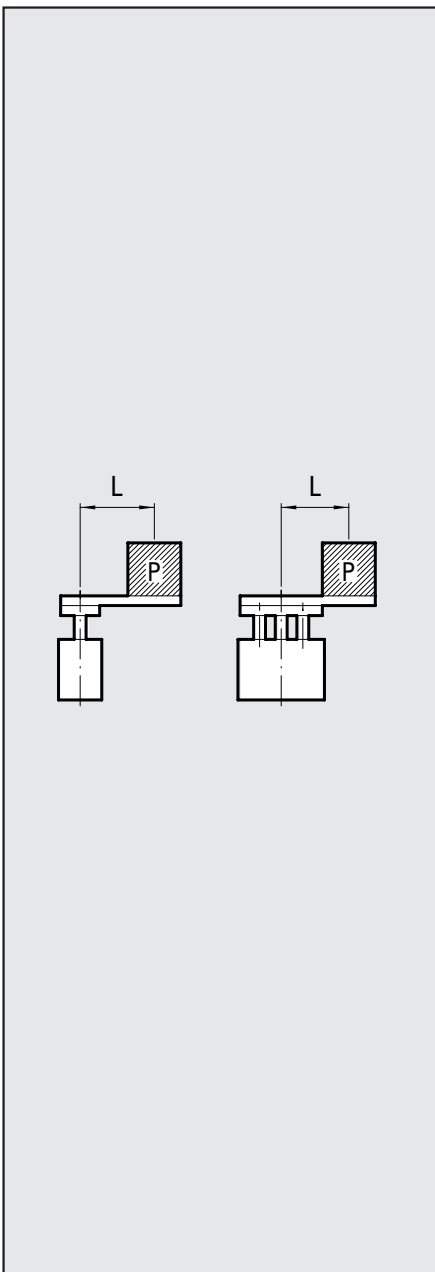

El grafico es referido a un cilindro carrera 25÷50 mm con guias de rodamiento de bolas

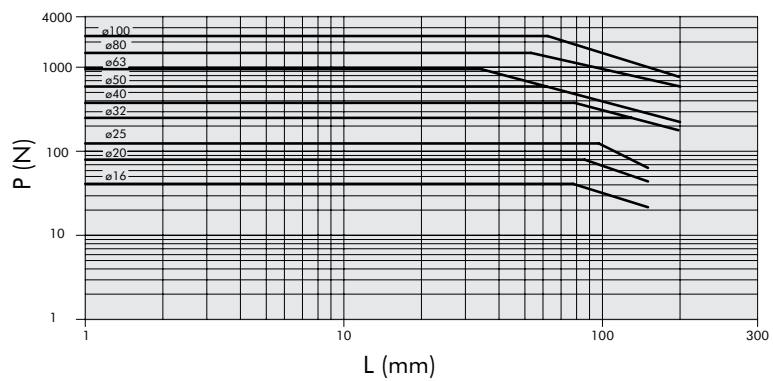

El grafico es referido a un cilindro carrera 75÷100 mm con guias de rodamiento de bolas

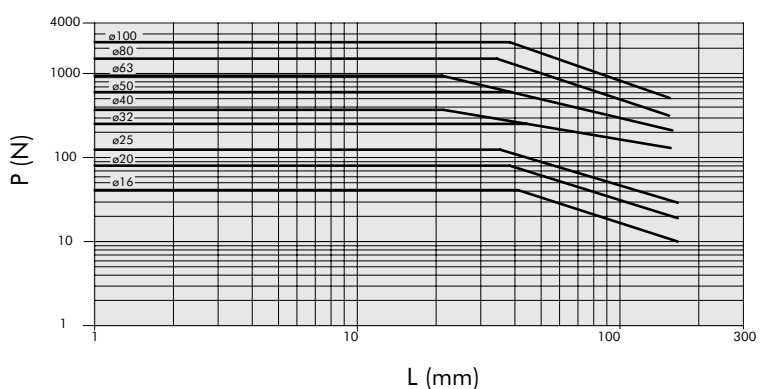

El grafico es referido a un cilindro carrera 50 mm con casquillo de bronce

DIMENSIONES CILINDRO COMPACTO GUIADO NO AMORTIGUADO Ø 16 ÷ 100

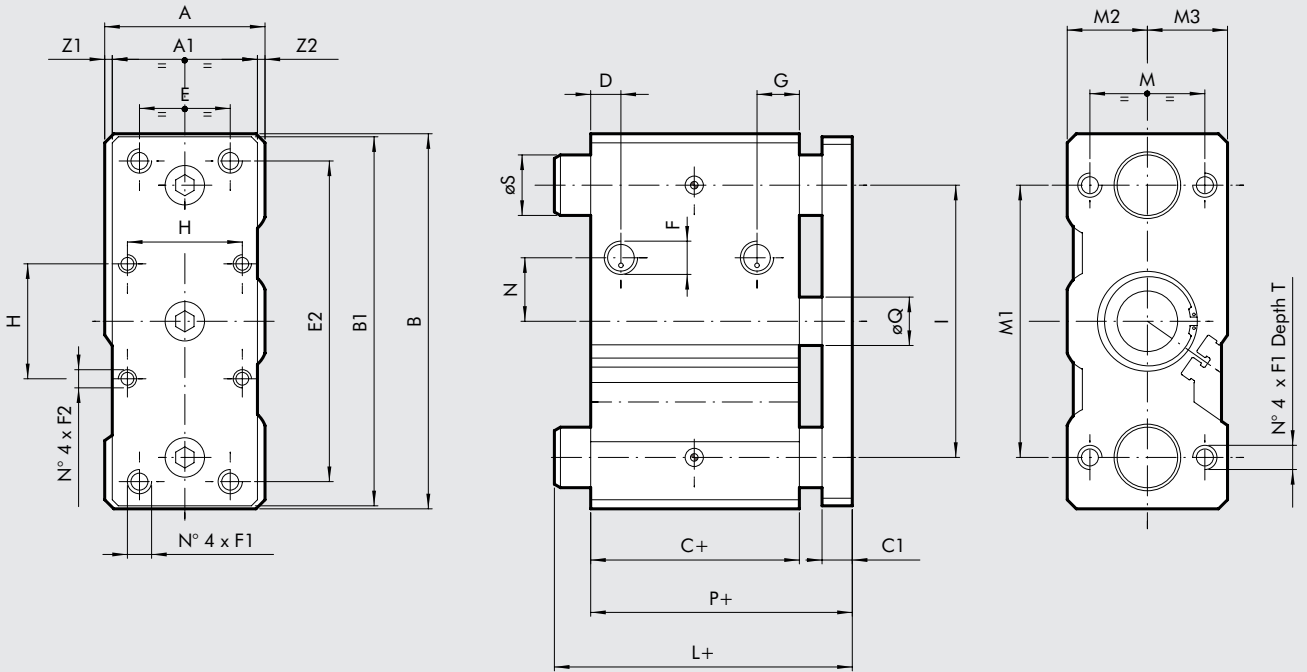

Ø	Ø S	
	Casquillo de bronce (BA)	Rodamiento de balos (BB)
16	10	10
20	12	10
25	16	16
32	20	20
40	20	20
50	**	**
63	**	**
80	28	25
100	35	30

** Para carreras 25 y 50 = 20
Para carreras ≥ 75 = 25

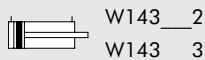

+ AÑADIR LA CARRERA

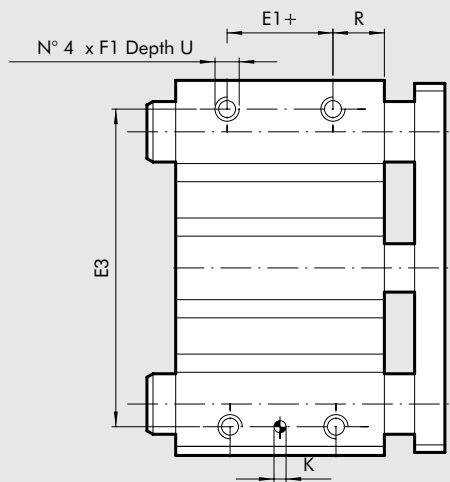

Ø	A	A1	B	B1	C	C1	D	E	E1	E2	E3	F	F1	F2	G	H	KH7	I	L	M	M1	M2	M3	N
16	33	25	64	62	33	10	9	16	7	52	54	M5	M5	-	10.5	-	4	38	*	22	42	15	18	8
20	36	29	74	72	37	10	9	18	10	60	64	1/8	M5	-	11	-	5	46	*	26	52	17	19	9
25	42	38	88	86	37.5	10	9	26	10	70	76	1/8	M6	-	11.5	-	5	56	*	32	62	21	21	8
32	51	49	114	112	37.5	10	9	30	5	96	100	1/8	M8	M6	12.5	32.5	6	80	73.5	38	80	25.5	25.5	15
40	51	49	124	122	44	10	11	30	10	106	110	1/8	M8	M6	14	38	6	90	73.5	38	90	25.5	25.5	21
50	59	56	140	138	44	12	11	40	10	120	124	1/4	M10	M8	14	46.5	6	100	83	44	100	29.5	29.5	27
63	72	69	150	148	49	12	11	50	10	130	132	1/4	M10	M8	14	56.5	6	110	83	44	110	36	36	31.5
80	92	88	188	185	56.5	16	15.5	60	15	160	166	3/8	M12	M10	19	72	6	140	93	56	140	46	46	37
100	112	108	224	221	66	16	19	80	15	190	200	3/8	M14	M10	23	89	8	170	105	62	170	56	56	40

Ø	P	ØQ	R	T	U	Z1	Z2
16	45	8	13	20	8	5.5	2.5
20	49	10	13	20	8	4.5	2.5
25	49.5	12	16.5	25	9	2	2
32	49.5	16	16	20	11	1.5	1.5
40	56	16	17	20	11	1.5	1.5
50	58	20	17	25	12.5	1.5	1.5
63	63	20	20	25	15	1.5	1.5
80	74.5	25	21	30	18	2	2
100	84	30	25	35	21	2	2

* =	L carrera	
	Ø	0÷50
16	45	-
20	49	76
25	49.5	79.5

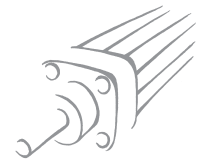

DIMENSIONES CILINDRO COMPACTO GUIADO AMORTIGUADO Ø 16÷63

1

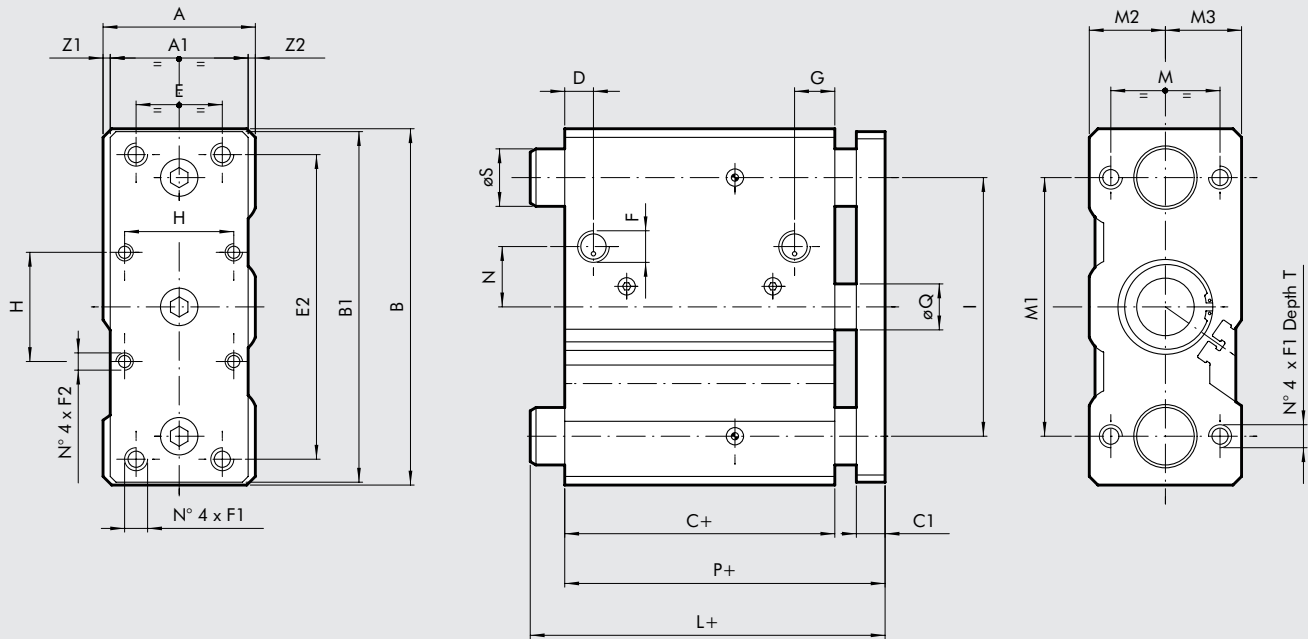

Ø	Ø S	
	Casquillo de bronce (BA)	Rodamiento de balos (BB)
16	10	10
20	12	10
25	16	16
32	20	20
40	20	20
50	**	**
63	**	**

** Para carreras 25 y 50 = 20
Para carreras ≥75 = 25

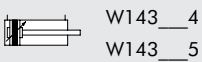

+ AÑADIR LA CARRERA

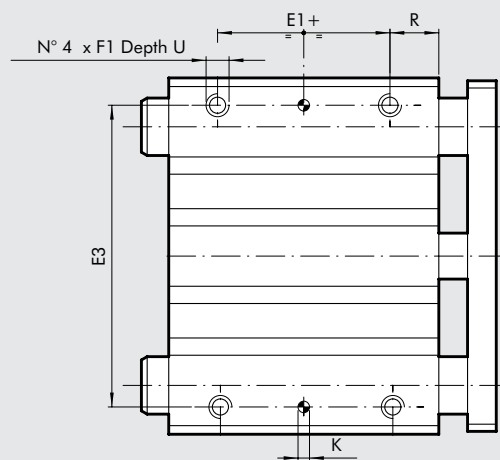

Ø	A	A1	B	B1	C	C1	D	E	E1	E2	E3	F	F1	F2	G	H	KH7	I	L	M	M1	M2	M3	N
16	33	25	64	62	58	10	9	16	32	52	54	M5	M5	-	10.5	-	4	40	*	22	42	15	18	8
20	36	29	74	72	62	10	9	18	35	60	64	1/8	M5	-	11	-	5	46	*	26	52	17	19	9
25	42	38	88	86	62.5	10	9	26	35	70	76	1/8	M6	-	11.5	-	5	56	*	32	62	21	21	8
32	51	49	114	112	62.5	10	9	30	30	96	100	1/8	M8	M6	12.5	32.5	6	80	106.5	38	80	25.5	25.5	15
40	51	49	124	122	69	10	11	30	35	106	110	1/8	M8	M6	14	38	6	90	106.5	38	90	25.5	25.5	21
50	59	56	140	138	69	12	11	40	35	120	124	1/4	M10	M8	14	46.5	6	100	118	44	100	29.5	29.5	27
63	72	69	150	148	74	12	11	50	35	130	132	1/4	M10	M8	14	56.5	6	110	118	44	110	36	36	31.5

Ø	P	ØQ	R	T	U	U1	Z1	Z2
16	◆	8	13	20	8	6	5.5	2.5
20	78	10	13	20	8	6	4.5	2.5
25	78.5	12	14	25	9	6	2	2
32	82.5	16	16.5	20	11	6	1.5	1.5
40	89	16	17	20	11	6	1.5	1.5
50	93	20	17	25	12.5	8	1.5	1.5
63	98	20	20	25	15	8	1.5	1.5

◆ para version BA (casquillo de bronce) = 78
para version BB (rodamineto de balos) = 75

Ø	L carrera	
	0÷50	75÷150
16	70	-
20	74	105.5
25	74.5	108.5

CLAVE DE CODIFICACIÓN CILINDRO COMPACTO GUIADO

W 1 4 3	0 3 2	2	0 2 5
TIPOLOGIA	DIÁMETRO	VERSIÓN	CARRERA
	16 20 25 32 40 50 63 *80 *A1=100	2 no amortiguado caquillo en bronce 3 no amortiguado casquillo rodamiento a bolas 4 amortiguado casquillo en bronce 5 amortiguado casquillo radamiento a bolas	VERSIÓN AMORTIGUADA Ø 16: 20, 30, 40, 50 Ø 20÷25: 20, 30, 40, 50, 75, 100, 150 Ø 32÷63: 25, 50, 75, 100, 150, 175 VERSIÓN NO AMORTIGUADA ♦ Ø 16: 10, 20, ● 25, 30, 40, 50, 75, 100, 150, 200 Ø 20÷25: 20, ● 25, 30, 40, 50, 75, 100, 150, 200 Ø 32÷100: 25, 50, 75, 100, 150, 200 ♦ Sobre demanda otras carreras. Pero las cotas del cilindro son las estandares en la carrera inmediata superior

* Solo para versión no amortiguada

● Solo para versión con casquillo de bronce

ACCESORIOS

SENSOR MAGNETICO INTEGRADO

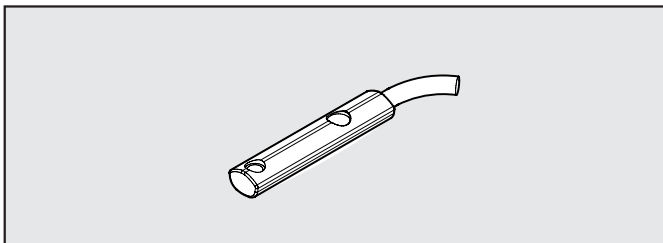

Códigos	Descripción
W0952025390	SENSOR HALL INST.VERT.2.5m
W0952029394	SENSOR HALL INST.VERT.M8
W0952022180	SENSOR REED INST.VERT.2.5m
W0952028184	SENSOR REED INST.VERT.M8
W0952125556	SENSOR HALL INST.VERT.NO 2m ATEX

Este tipo de sensor tiene la característica de poder ser montado en la ranura del sensor directamente desde arriba. Por esto las culatas del cilindro no necesitan de una apertura pasante.

ESQUEMA ELÉCTRICO

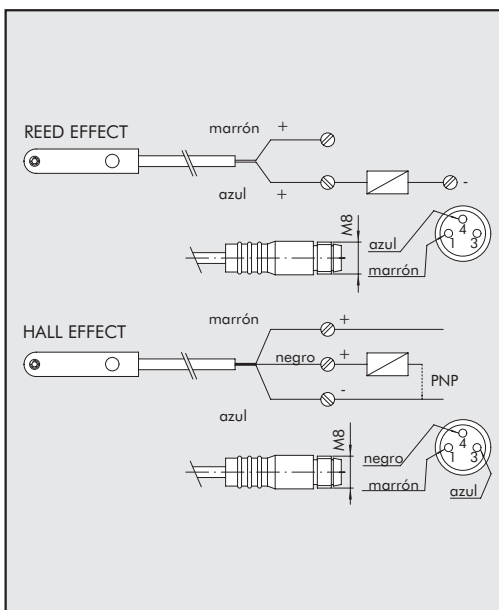

DATOS TÉCNICOS

	Reed	Effetto Hall	ATEX
Tipo contacto	N.O.	N.O.	N.O.
Interruptor	-	PNP	PNP
Tensión de alimentación (Ub)	V 10 ÷ 30 AC/DC	10 ÷ 30 DC	18 ÷ 30 DC
Potencia	W 3 (peak valve=6)	3	≤ 1.7
Variación de tensión	-	≤ 10% di Ub	≤ 10% di Ub
Caída de tensión	-	≤ 2	≤ 2.2
Consumo	mA -	≤ 10	≤ 10
Corriente de salida	mA ≤ 100	≤ 100	≤ 70
Frecuencia de conmutación	Hz ≤ 400	≤ 5	1000
Protección de corto circuito	-	Si	Si
Sobre tensión	-	Si	Si
Protección al invertir polaridad	-	Si	Si
EMC	EN 60 947-5-2	EN 60 947-5-2	EN 60 947-5-2
Visualización comunicación Led	Amarillo	Amarillo	Amarillo
Sensibilidad magnética	2,8 mT ±25%	2,8 mT ±25%	2.6
Frecuencia	≤ 0,1 mT	≤ 0,1 mT	≤ 0,1 (Ub e ta costanti)
Grado de protección (EN 60529)	IP 67	IP 67	IP 68, IP 69K
Resistencia a la vibración e impactos	30 g, 11 ms, 10÷55 Hz, 1mm -25 ÷ +75	30 g, 11 ms, 10÷55 Hz, 1mm -25 ÷ +75	30 g, 11 ms, 10÷55 Hz, 1mm -20 ÷ +45
Material cápsula sensor	PA66 + PA6I/6T	PA66 + PA6I/6T	PA
Cable de conexión 2,5m	PVC; 2 x 0,12 mm ²	PVC; 3 x 0,14 mm ²	PVC; 3 x 0,12 mm ²
Cable de conexión con M8x1	Poliuretano; 2 x 0,14 mm ²	Poliuretano; 3 x 0,14 mm ²	-
Numero conductores	2	3	3

RAIL PARA RANURA PORTA-SENSOR

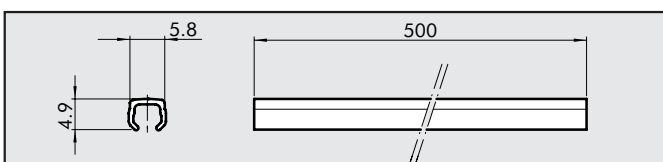

Código	Descripción
W0950000160	RAIL PARA RANURA PORTA-SENSOR

Nota: al código corresponde n. 1 pieza