

CILINDRO COMPACTO SERIE "CMPC" Ø 12÷100

Cilindro compacto serie CMPC disponible en multiples versiones en grado de satisfacer las diferentes exigencias del mercado

- ejecucion magnetico y no magnetico
- simple efecto vastago salido, entrado y pasante
- version antirrotacion doble efecto y doble efecto vastago pasante
- tandem de dos, tres y cuatro modulos
- tandem varias carreras de dos y tres modulos
- fijaciones compatibles a normas ISO 15552 del Ø 32 al Ø 100 mm del Ø 20 al Ø 100 compatible a norma NFE 49-004-1 y 2 (UNITOP), el Ø 12 y Ø 16 con fijaciones compatibles a los cilindros más comunes en el mercado.

El particular perfil y la testera montada en la camisa con tornillos autoformantes aseguran un cilindro con un guiado optimo y gracias a la amplia gama de fijaciones, obtenemos numerosas posibilidades de montaje.

Para el montaje del sensor magnetico de proximidad, el perfil del cilindro esta adecuado con una ranura para su rapido montaje.

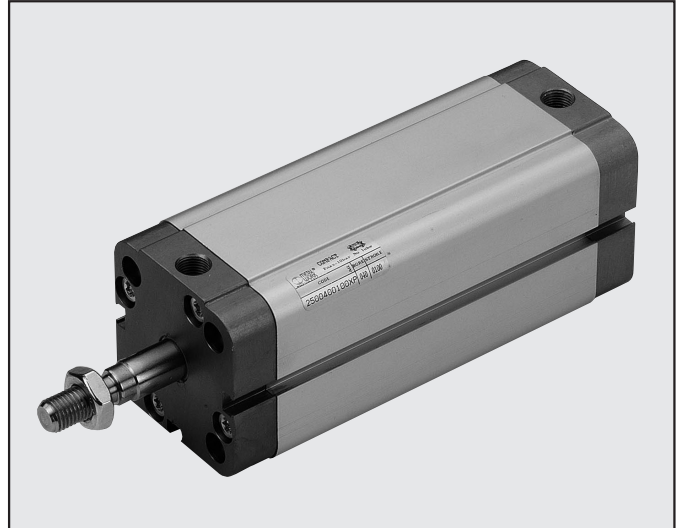

DATOS TÉCNICOS	POLIURETANO
Presión de trabajo	max 10 bar (max 1 MPa-145 psi)
Temperatura de trabajo	-10°C ÷ +80°C
Fluido	Aire no lubricado, si utiliza aire lubricado, la lubricación debe ser continua
Carrera standard	Ver PAG. 1.1/36
Fijaciones	mm Ø 12; Ø 16; intercambiable con productos análogos
	mm Ø 32; Ø 40; Ø 50; Ø 63; Ø 80; Ø 100 fijaciones norma ISO15552
	mm Ø 20; Ø 25; Ø 32; Ø 40; Ø 50; Ø 63; Ø 80; Ø 100 fijaciones norma NFE 49-004-1 y 2 (UNITOP)
Tipo de construcción	Camisa aluminio, testera con tornillos autoformantes
Versiones	Doble efecto, simple efecto vástago retraído y salido, vástago pasante, simple efecto vástago pasante, doble efecto antirrotacion, simple efecto antirrotacion. Todas las versiones tienen la posibilidad de rosca macho o hembra en vástago
Magneto para sensor	Todas las versiones son completas de magneto, sobre pedido puede ser sin magneto
Nota de uso	Para su correcto funcionamiento es aconsejable usar aire filtrado a 50 µm Para versiones anti stick slip utilizar sólo aire sin lubricación
Presión de arranque	de Ø 12 a Ø 32: 0,6 bar - de Ø 40 a Ø 100: 0,4 bar
Fuerzas desarrolladas a 6 bar empuje/tracción	Ver DATOS TECNICOS GENERALES PAG. 1.1/05
Peso	Ver DATOS TECNICOS GENERALES PAG. 1.1/06

COMPONENTES Ø 12÷25

- ① VASTAGO: acero inox, cromado a espesor
- ② TESTERA: en aluminio anodizado
- ③ CAMISA: en aluminio perfilado, anodizado y calibrado
- ④ JUNTAS EMBOLO: poliuretano
- ⑤ MAGNETO: neodimio
- ⑥ JUNTAS VASTAGO: poliuretano
- ⑦ CASQUILLO DE GUIA: fleje de acero con recubrimiento de bronce y PTFE
- ⑧ OR estaticas: NBR
- ⑨ TORNILLOS FIJACION: acero cincado

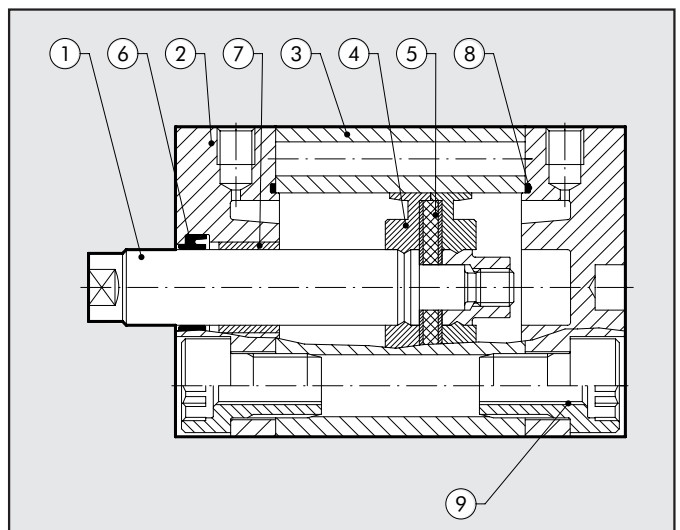



COMPONENTES Ø 32 ÷ 100

- ① VÁSTAGO: acero C45 o inox, cromado a espesor
- ② TESTARA: en aluminio anodizado
- ③ CAMISA: en aluminio perfilado, anodizado y calibrado
- ④ JUNTAS EMBOLO: poliuretano
- ⑤ MAGNETO: Ø 12 ÷ 32 neodimio - Ø 40 ÷ 100 plastoferrita
- ⑥ JUNTAS VÁSTAGO: poliuretano
- ⑦ CASQUILLO GUIA: fleje de acero con recubrimiento de bronce y PTFE
- ⑧ OR estaticas: NBR
- ⑨ TORNILLOS DE FIJACIÓN: acero cincado

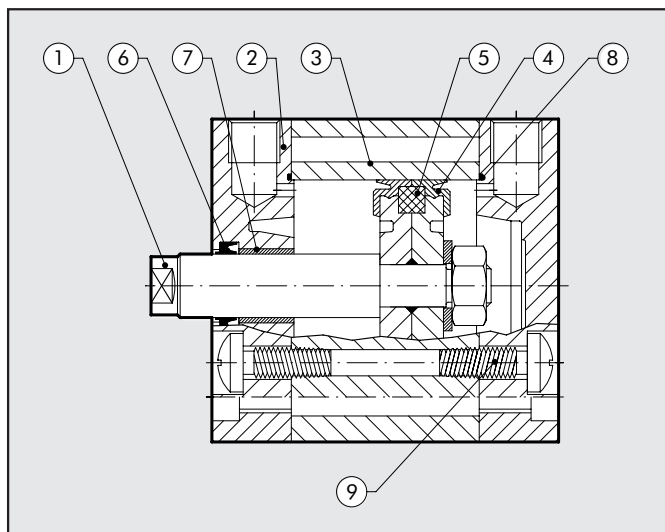

CARACTERÍSTICAS

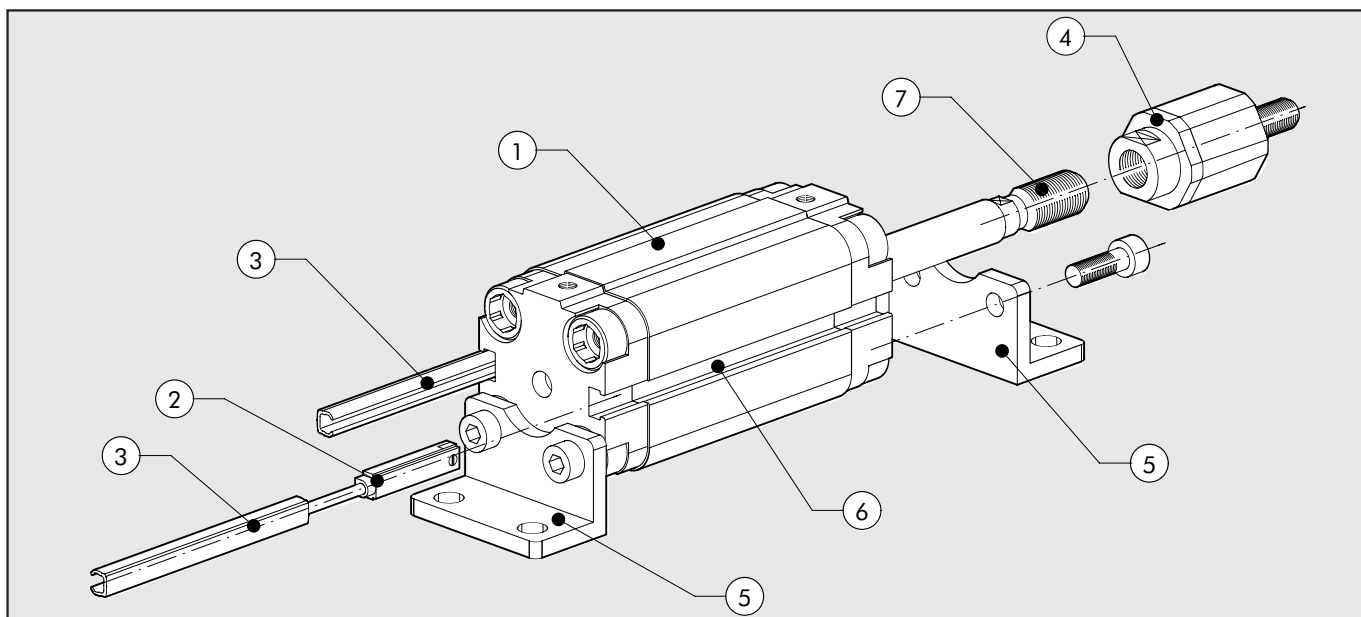

- ① Cilindro compacto disponible en dos normas de fijación:
 - Ø 32 ÷ 100 compatible a la norma ISO15552
 - Ø 20 ÷ 100 compatible a la norma NFE 49-004-1 y 2 (UNITOP)
- ② Sensor magnético precableado con o sin conector
- ③ Varilla de plástico antisuciedad y protección cable sensor W0950000160
- ④ Rotula autoalineante cod. W095...2030
- ⑤ Ejemplo de montaje cilindro con patas cod. W095...6001
todas las fijaciones están completas de tornillos para montaje en cilindro
- ⑥ Ranura porta sensor
- ⑦ Vástago con rosca macho o hembra según necesidad

POSIBILIDADES DE MONTAJE CILINDRO COMPACTO

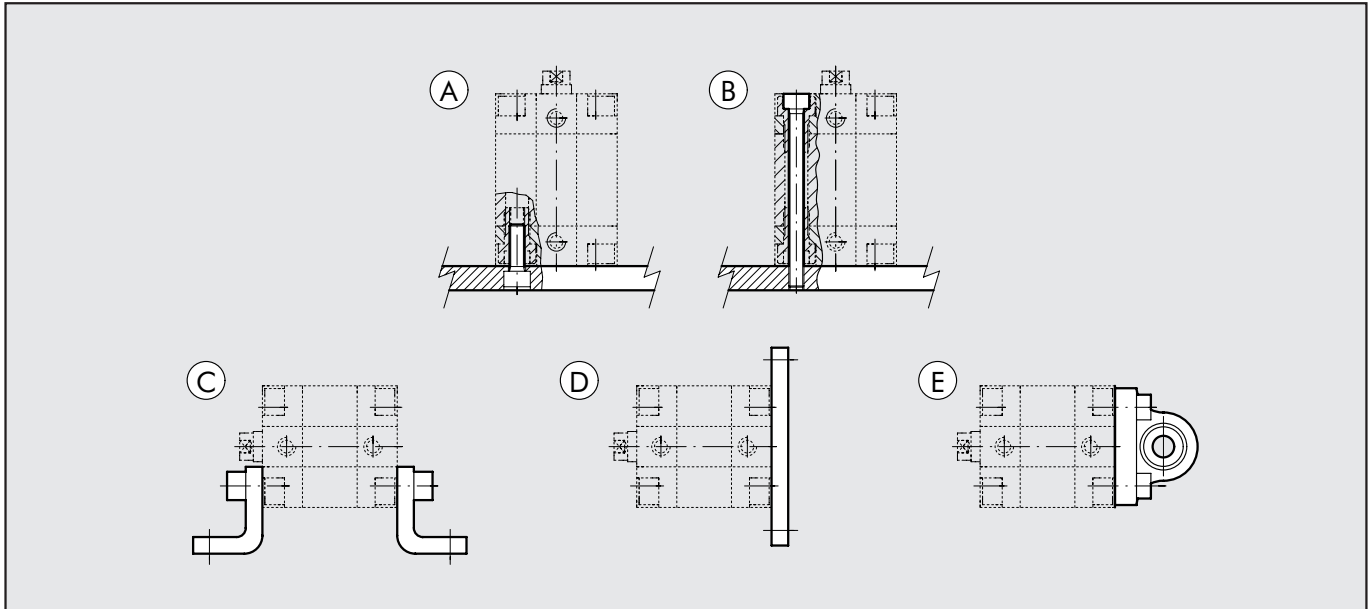

- (A) Fijación vertical por tornillo pasante y roscado a la culata.
 (B) Fijación vertical por tornillo pasante total y roscado a pletina.
 (C) Fijación con patas, el código de pedido comprende (1) pata y (2) tornillos.
 (D) Fijación con brida montada sobre culata delantera o trasera, el código de pedido comprende (1) brida y (4) tornillos de fijación.
 (E) Fijación con charnela con rotula, permite recuperar un ligero desajuste de alineamiento del sistema, el código de pedido comprende (1) charnela rotula y (4) tornillos de fijación.

FUERZA DEL MUELLE DEL CILINDRO SIMPLE EFECTO (TEORICA)

Diámetro	Ø 12	Ø 16	Ø 20	Ø 25	Ø 32	Ø 40	Ø 50	Ø 63	Ø 80	Ø 100
Fuerza min. (N)	4.40	4.90	8.40	13.90	19.00	24.80	36.30	50.20	77.60	131.80
Fuerza max. (N)	9.80	14.20	20.90	33.20	35.90	53.70	62.20	82.30	118.90	183.30

CARRERAS PARA CILINDROS COMPACTOS

Carrera standard para simple efecto	Carrera standard otras tipologías	Carrera max. aconsejable otras tipologías	Carrera max. para antirotación
Ø 12 → 10 mm	Ø 12; Ø 16 → da 5 a 40 mm	Ø 12÷Ø 25 → 200 mm	Ø 12÷Ø 63 → 120 mm
Ø 16; Ø 100 → 25 mm	Ø 20; Ø 25 → da 5 a 50 mm	Ø 32; Ø 40 → 300 mm	Ø 80; Ø 100 → 150 mm
	Ø 32÷Ø 100 → da 5 a 80 mm	Ø 50; Ø 63 → 400 mm	
		Ø 80; Ø 100 → 500 mm	

Carrera max. para vástago pasante hueco

Ø 20÷Ø 40 → 5 a 80 mm
Ø 50; Ø 63 → 5 a 100 mm
Ø 80; Ø 100 → 5 a 160 mm

carreras máximas aconsejables, valores superiores pueden crear problemas de funcionamiento.

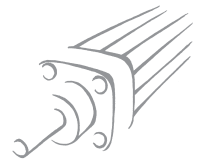

ESQUEMA DE MONTAJE VÁLVULA SOBRE CILINDRO

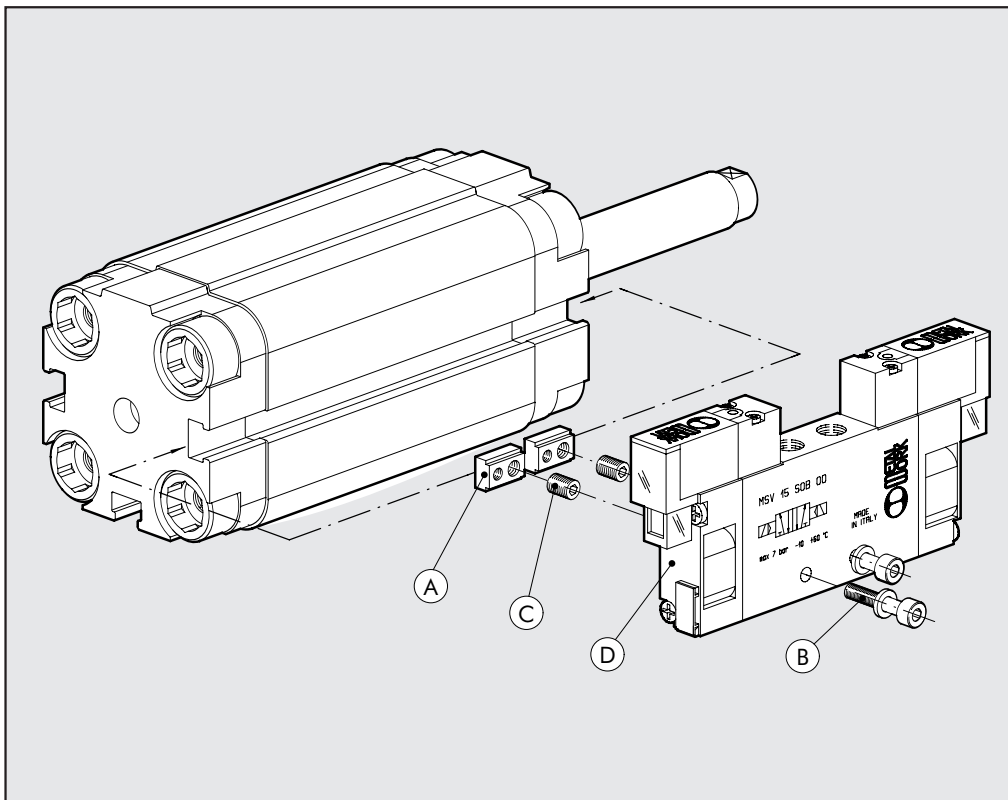

Con esta tipología de cilindros, la válvula D pueden ir montadas directamente encima del cilindro sin usar una placa intermedia, aprovechando el rail de los sensores integrados. Esto es posible utilizando una placa especial (A) roscada a M3 o M4 y los tornillos (B) cuya medida, tipo y cantidad están indicadas en la tabla adjunta. La placa especial, viene completa con dos tornillos, uno M3 y otro M4 (C). Una vez fijada la válvula al cilindro, la placa especial también puede ser utilizada como posicionador de memoria en el caso del posible mantenimiento de la válvula.

Tipo de válvula para montar (D)	Placa de fijación (A) cod. 0950003000	Memoria de Posic.: tornillo (C) de utilizar	Tornillo (B) de montaje al cilindro (uno por placa)	Arandela (B) (una por tornillo)
MACH 11	n. 2	M4	M3x16 UNI 5931 (DIN 912)	A3.2 UNI 1751 (DIN 127A)
SERIE 70 1/8	n. 2	M3	M4x25 UNI 5931 (DIN 912)	—
SERIE 70 1/4	n. 2	M3	M4x30 UNI 5931 (DIN 912)	A4.3 UNI 1751 (DIN 127A)

CARGAS MÁXIMAS VERSIÓN ANTIRROTACIÓN

FUERZA TRANSVERSAL ANTIRROTACIÓN

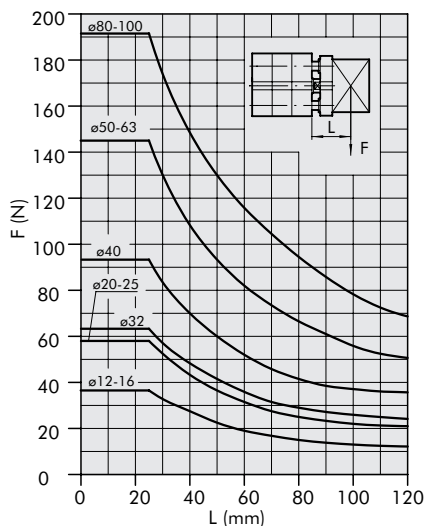

FUERZA TRANSVERSAL ANTIRROTACIÓN VASTAGO PASANTE

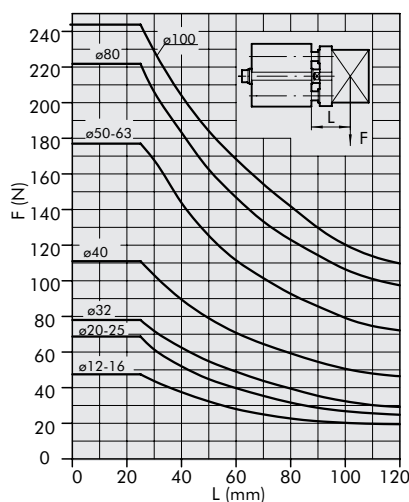

TORSION EN FUNCIÓN DE LA CARRERA

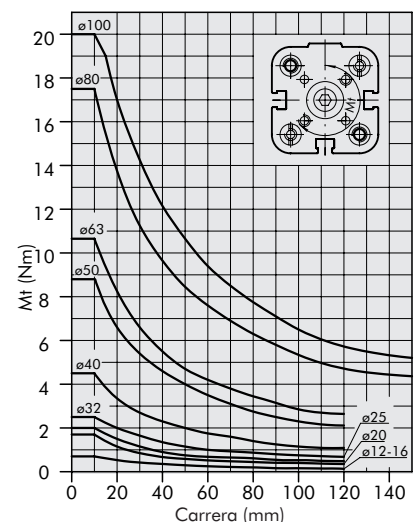

DIMENSIONES VERSIÓN: DOBLE EFECTO Ø 12÷D.25 - SIMPLE EFECTO Ø 12÷25

+ = AÑADIR LA CARRERA
1 = RANURA PARA SENSOR

SE-DE VÁSTAGO MACHO

SE VÁSTAGO EXTENDIDO

SE VÁSTAGO EXTENDIDO MACHO

	A	B	ØC	CH	CH1	D	ØEH	F	G	H	H1	L	M	N	O	ØO1	P	Q	R	S	S1	NORMA
Ø 12	29	18	6	5	10	30	6	4	38	8	30	18.5	8	42.5	M4	3.2	M3	M5	M6	16	4.5	
Ø 16	29	18	8	7	13	30	6	4	38	8	30	18.5	10	42.5	M4	3.2	M4	M5	M8	20	4.5	
Ø 20	36.5	22	10	8	17	37.5	6	4	38	8	30	18.5	12	42.5	M5	4.2	M5	M5	M10x1.25	22	4.5	UNITOP
Ø 25	40.5	26	10	8	17	41.5	6	4	39.5	8	31.5	19	12	45	M5	4.2	M5	M5	M10x1.25	22	5.5	UNITOP

DIMENSIONES VERSIÓN: DOBLE EFECTO Ø 32÷100 - SIMPLE EFECTO Ø 32÷100

+ = AÑADIR LA CARRERA
1 = RANURA PARA SENSOR
7 = SOLO DEL Ø 63 AL Ø 100
8 = REBAJE PARA TORNILLO DIN 7984

SE-DE VÁSTAGO MACHO

SE VÁSTAGO EXTENDIDO

SE VÁSTAGO EXTENDIDO MACHO

	B		ØC	CH	CH1	D	ØEH	F	G	H	H1	L	M	N	O		ØO1		P	Q	R	S	S1		
	A	ISO													UNITOP	ISO	UNITOP	ISO						UNITOP	
Ø 32	47	32.5 ^{+0.4}	32 ^{+0.4}	-	12	10	17	48.5	6	4	44.5	7.5	37	4	14	50.5	M6	M6	5.2	5.2	M6	G1/8	M10x1.25	22	6
Ø 40	56	38	42	-	12	10	17	57.5	6	4	45.5	7.5	38	4.5	14	52	M6	M6	5.2	5.2	M6	G1/8	M10x1.25	22	6.5
Ø 50	67	46.5	50	-	16	13	19	69	6	4	45.5	7.5	38	4.5	16	53	M8	M8	6.2	6.2	M8	G1/8	M12x1.25	24	7.5
Ø 63	80	56.5	62	13	16	13	19	82	8	4	50	7.5	42.5	5.5	16	57.5	M8	M10	6.2	8.5	M8	G1/8	M12x1.25	24	7.5
Ø 80	102	72	82	17	20	17	24	105	8	4	56	8.5	47.5	5.5	20	64	M10	M10	8.5	8.5	M10	G1/8	M16x1.5	32	8
Ø 100	123	89	103	21	25	22	30	126	8	4	66.5	10.5	56	5.5	24	76.5	M10	M10	8.5	8.5	M12	G1/4	M20x1.5	40	10



DIMENSIONES VERSIÓN: ANTIRROTACIÓN Ø 12 ÷ 25 MM

1

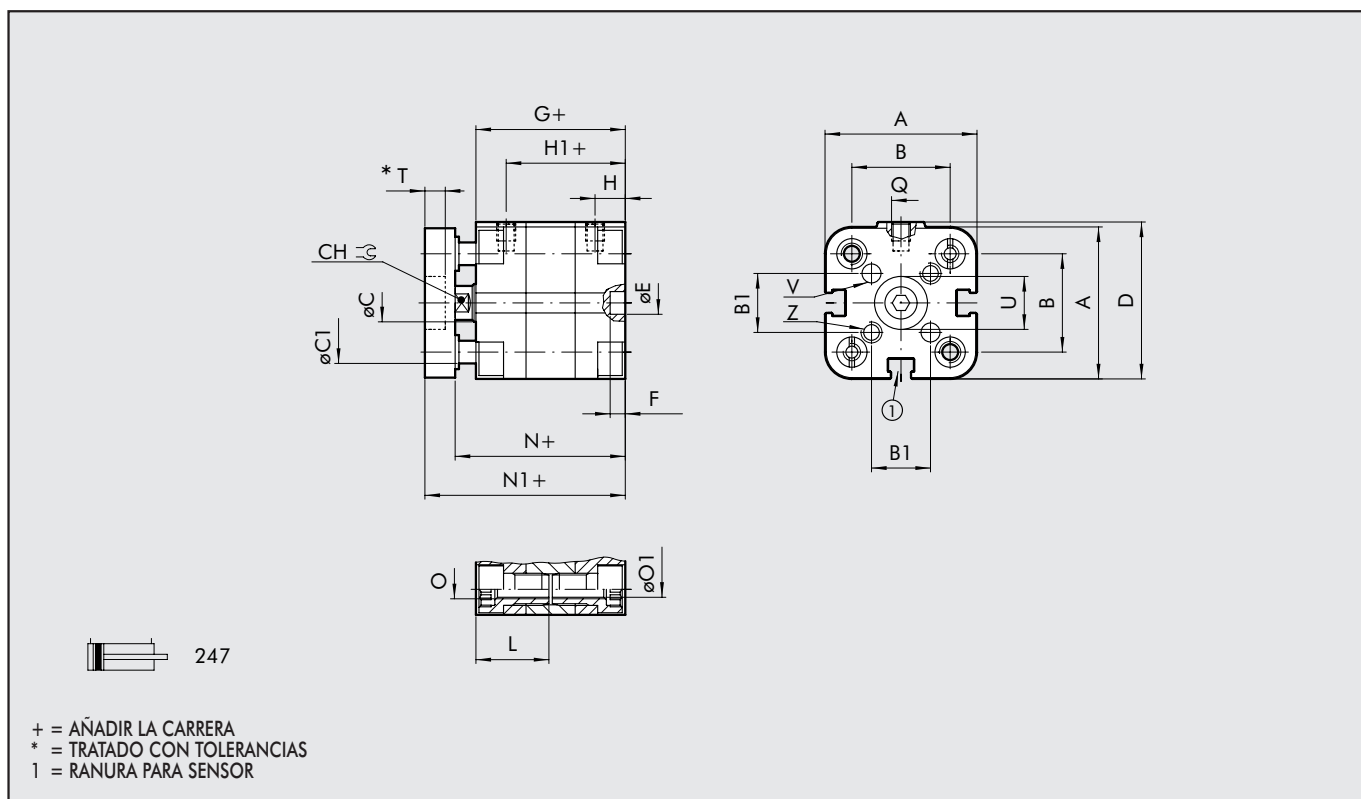

ANTIRROTACIÓN VÁSTAGO PASANTE HEMBRA

ANTIRROTACIÓN VÁSTAGO PASANTE MACHO

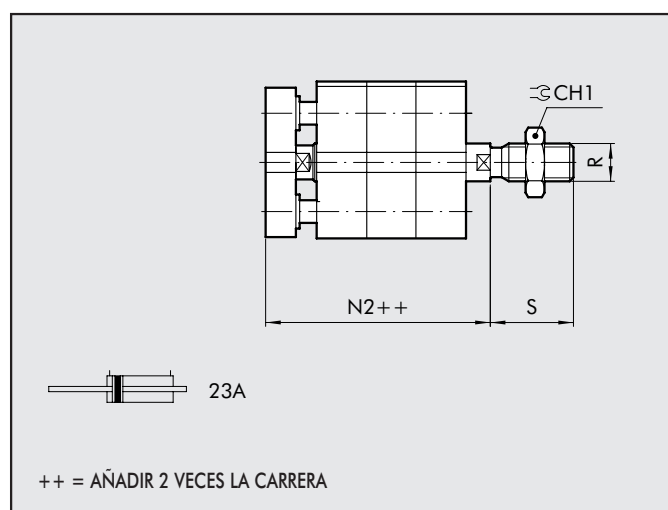
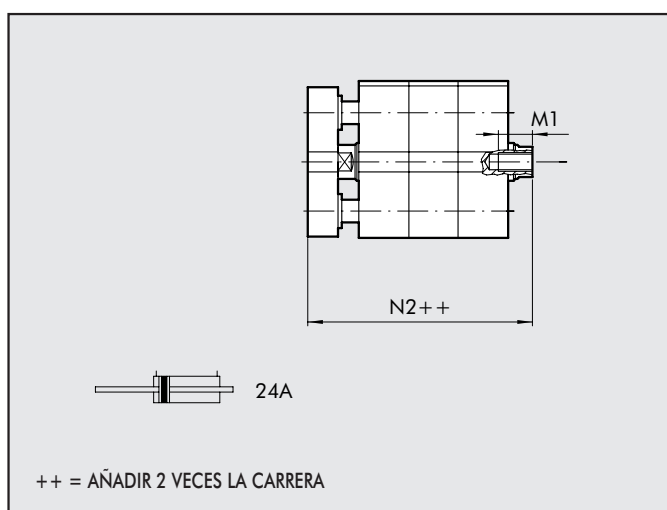

	A	B	B1	ØC	ØC1	CH	CH1	D	ØE H9	F	G	H	H1	L	M1 x carrera		N	N1	N2
															<5	≥5			
Ø 12	29	18	9.9	6	5	5	10	30	6	4	38	8	30	18.5	5	8	42.5	48.5	53
Ø 16	29	18	9.9	8	5	7	13	30	6	4	38	8	30	18.5	5	10	42.5	48.5	53
Ø 20	36.5	22	12	10	6	8	17	37.5	6	4	38	8	30	18.5	7	12	42.5	50.5	55
Ø 25	40.5	26	15.6	10	6	8	17	41.5	6	4	39.5	8	31.5	19	7	12	45	53	58.5

	O	ØO1	P	Q	R	S	T	ØU H9	ØV H8	Z	NORMA
Ø 12	M4	3.2	M3	M5	M6	16	2	6	3	M3	
Ø 16	M4	3.2	M4	M5	M8	20	2	8	3	M3	
Ø 20	M5	4.2	M5	M5	M10x1.25	22	3.5	10	4	M4	UNITOP
Ø 25	M5	4.2	M5	M5	M10x1.25	22	4	14	5	M5	UNITOP

DIMENSIONES ANTIRROTACIÓN Ø 32 ÷ 100

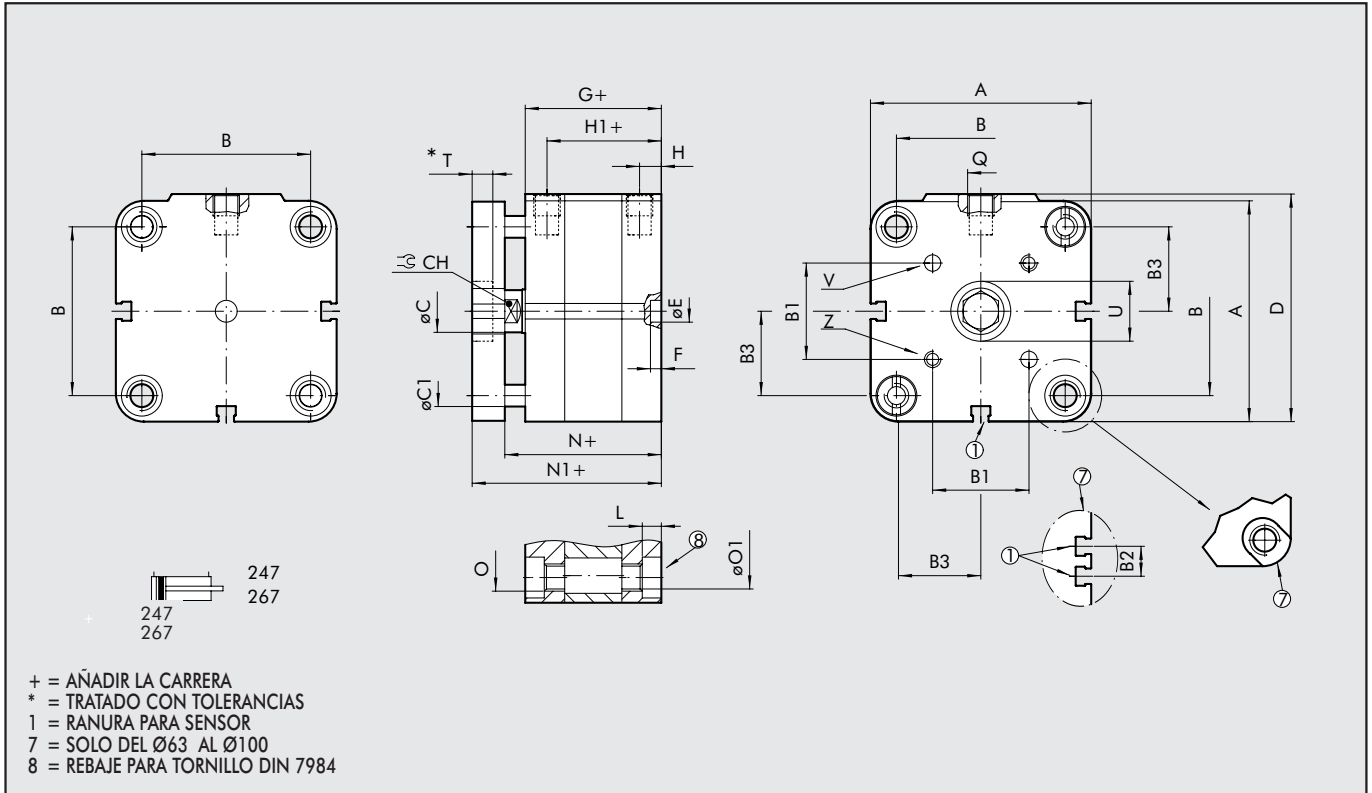

ANTIRROTACIÓN VÁSTAGO PASANTE HEMBRA

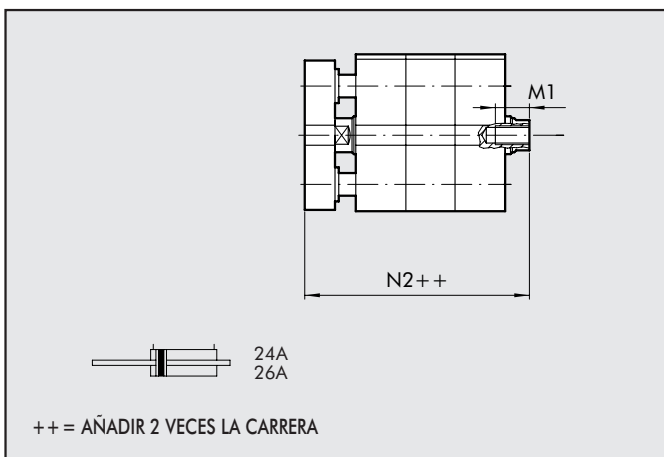

ANTIRROTACIÓN VÁSTAGO PASANTE MACHO

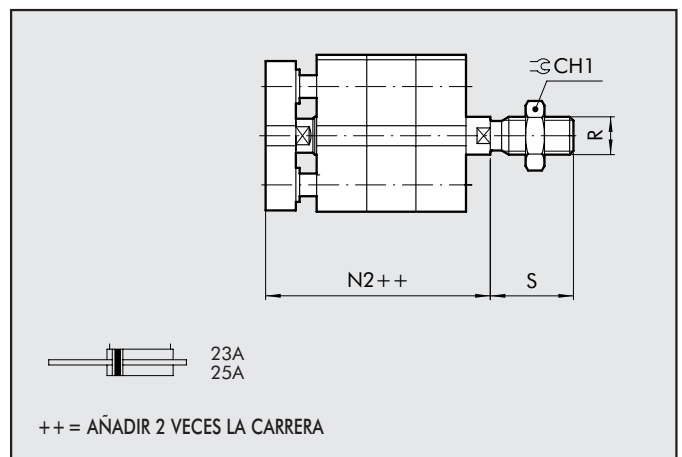

Ø	A	B		B1	B2	B3	ØC	ØC1	CH	CH1	D	ØE H9	F	G	H	H1	L	M1 x carrera	
		ISO	UNITOP															≥5	<5
Ø 32	47	32.5 ^{+0.1}	32 ^{+0.1}	19.8	-	16.1	12	8	10	17	48.5	6	4	44.5	7.5	37	4	14	9
Ø 40	56	38	42	23.3	-	20	12	8	10	17	57.5	6	4	45.5	7.5	38	4.5	14	9
Ø 50	67	46.5	50	29.7	-	24	16	10	13	19	69	6	4	45.5	7.5	38	4.5	16	11
Ø 63	80	56.5	62	35.4	13	30	16	10	13	19	82	8	4	50	7.5	42.5	5.5	16	11
Ø 80	102	72	82	46	17	38.5	20	12	17	24	105	8	4	56	8.5	47.5	5.5	20	15
Ø 100	123	89	103	56.6	21	48	25	12	22	30	126	8	4	66.5	10.5	56	5.5	24	19

Ø	O			ØO1		P	Q	R	S	T	ØU H9	ØV H8	Z		
	N	N1	N2	ISO	UNITOP										
Ø 32	50.5	60.5	66.5	M6	M6	5.2	5.2	M6	G1/8	M10x1.25	22	4.5	17	5	M5
Ø 40	52	62	68.5	M6	M6	5.2	5.2	M6	G1/8	M10x1.25	22	4.5	17	5	M5
Ø 50	53	65	72.5	M8	M8	6.2	6.2	M8	G1/8	M12x1.25	24	6	22	6	M6
Ø 63	57.5	69.5	77	M8	M10	6.2	8.5	M8	G1/8	M12x1.25	24	6	22	6	M6
Ø 80	64	78	86	M10	M10	8.5	8.5	M10	G1/8	M16x1.5	32	8	28	8	M8
Ø 100	76.5	90.5	100.5	M10	M10	8.5	8.5	M12	G1/4	M20x1.5	40	9	30	10	M10

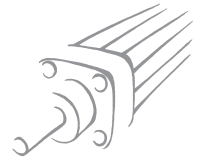

DIMENSIONES VÁSTAGO PASANTE Ø 12 ÷ 25

+ = AÑADIR LA CARRERA
 ++ = AÑADIR 2 VECES LA CARRERA
 1 = RANURA PARA SENSOR

SE-DE VÁSTAGO MACHO PASANTE HUECO

	A	B	ØC	CH	CH1	D	G	H	H1	L	M	M1xcarrera		N	N2	O	ØO1	P	P1	P2	Q	R	S
												<5	≥5										
Ø 12	29	18	6	5	10	30	38	8	30	18.5	8	5	8	42.5	47	M4	3.2	M3	-	-	M5	M6	16
Ø 16	29	18	8	7	13	30	38	8	30	18.5	10	5	10	42.5	47	M4	3.2	M4	-	-	M5	M8	20
Ø 20*	36.5	22	10	8	17	37.5	38	8	30	18.5	12	7	12	42.5	47	M5	4.2	M5	-	1.5	M5	M10x1.25	22
Ø 25*	40.5	26	10	8	17	41.5	39.5	8	31.5	19	12	7	12	45	50.5	M5	4.2	M5	-	1.5	M5	M10x1.25	22

*Construido según norma UNITOP

DIMENSIONES VÁSTAGO PASANTE Ø 32 ÷ 100

+ = AÑADIR LA CARRERA
 ++ = AÑADIR 2 VECES LA CARRERA
 1 = RANURA PARA SENSOR
 7 = SOLO DEL Ø 63 AL Ø 100
 8 = REBAJE PARA TORNILLO DIN 7984

SE-DE VÁSTAGO MACHO PASANTE HUECO

	A	ISO	B	UNITOP	B2	ØC	CH	CH1	D	G	H	H1	L	M	M1xcarrera		N	N2	ISO	UNITOP	O	ØO1		P	P1	P2	Q	R	S
															≥5	<5						ISO	UNITOP						
Ø 32	47	32.5 ^{+0.4}	32 ^{+0.4}	-	12	10	17	48.5	44.5	7.5	37	4	14	14	9	50.5	56.5	M6	M6	5.2	5.2	M6	-	2.5	G1/8	M10x1.25	22		
Ø 40	56	38	42	-	12	10	17	57.5	45.5	7.5	38	4.5	14	14	9	52	58.5	M6	M6	5.2	5.2	M6	-	2.5	G1/8	M10x1.25	22		
Ø 50	67	46.5	50	-	16	13	19	69	45.5	7.5	38	4.5	16	16	11	53	60.5	M8	M8	6.2	6.2	M8	-	4	G1/8	M12x1.25	24		
Ø 63	80	56.5	62	13	16	13	19	82	50	7.5	42	5.5	16	16	11	57.5	65	M8	M10	6.2	8.5	M8	-	4	G1/8	M12x1.25	24		
Ø 80	102	72	82	17	20	17	24	105	56	8.5	47.5	5.5	20	20	15	64	72	M10	M10	8.5	8.5	M10	1/8	5	G1/8	M16x1.5	32		
Ø 100	123	89	103	21	25	22	30	126	66.5	10.5	56	5.5	24	24	19	76.5	86.5	M10	M10	8.5	8.5	M12	1/4	6	G1/4	M20x1.5	40		

DIMENSIONES CILINDRO TANDEM Ø 12÷25 - 4 MODULOS

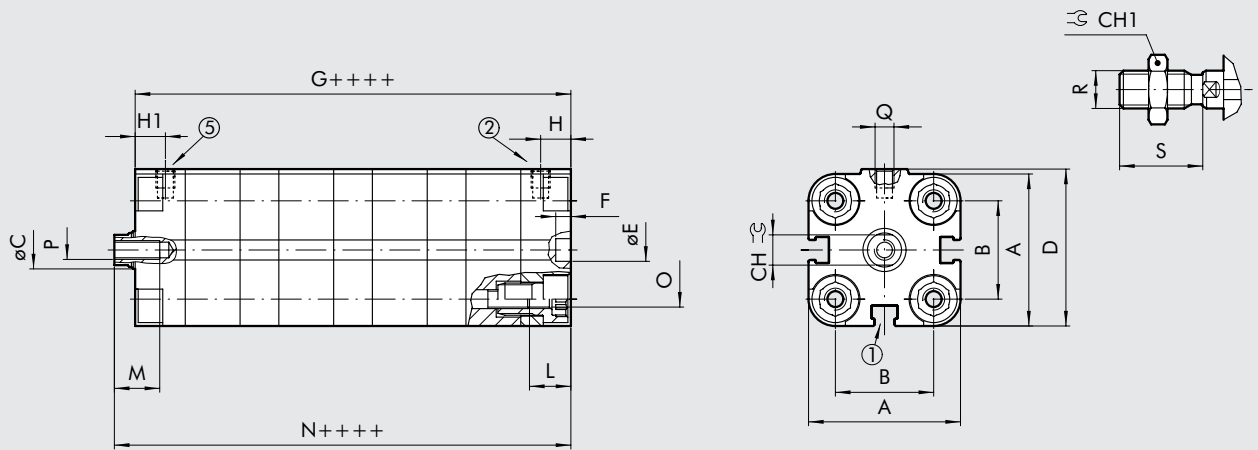

++++ = AÑADIR 4 VECES LA CARRERA
 1 = RANURA PARA SENSOR
 2 = ALIMENTACIÓN EN SALIDA CILINDRO
 5 = ALIMENTACIÓN EN ENTRADA CILINDRO

3 MODULOS

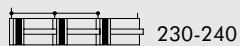
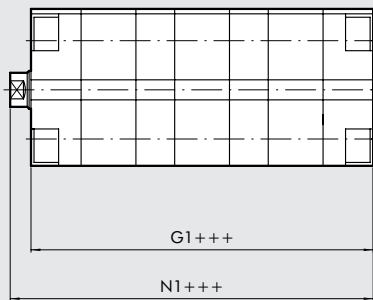

+++ = AÑADIR 3 VECES LA CARRERA

2 MODULOS

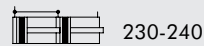
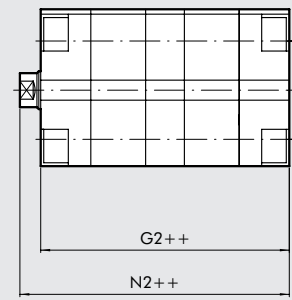

++ = AÑADIR 2 VECES LA CARRERA

	A	B	ØC	CH	CH1	D	ØE H9	F	G	G1	G2	H	H1	L	M	N	N1
Ø 20	36.5	22	10	8	17	37.5	6	4	114.5	89	63.5	8	8	10	12	119	93.5
Ø 25	40.5	26	10	8	17	41.5	6	4	118	92	66	8	8	10	12	123.5	97.5

N2	O	P	Q	R	S	Norma
68	M5	M5	M5	M10x1.25	22	UNITOP
71.5	M5	M5	M5	M10x1.25	22	UNITOP



DIMENSIONES CILINDRO TANDEM Ø 32÷100 - 4 MODULOS

1

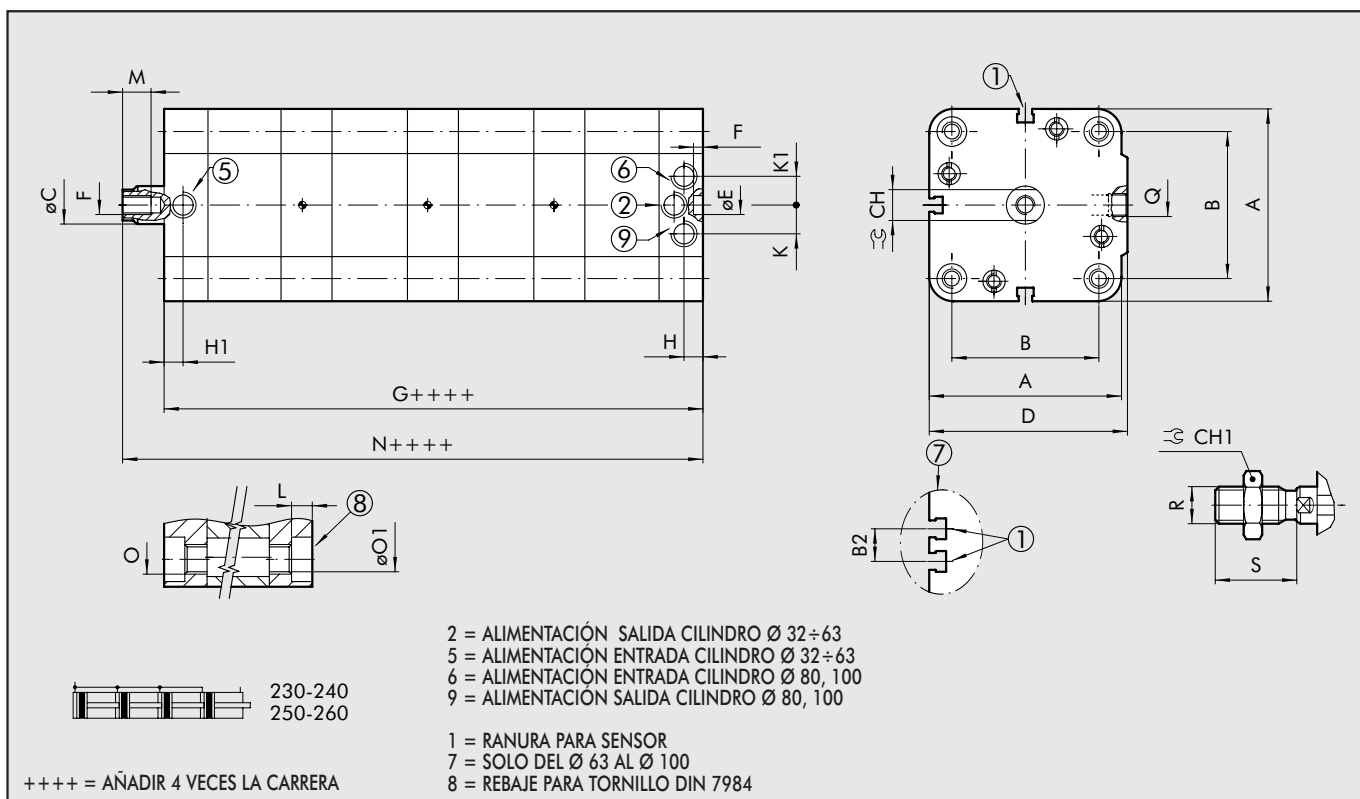

3 MODULOS

2 MODULOS

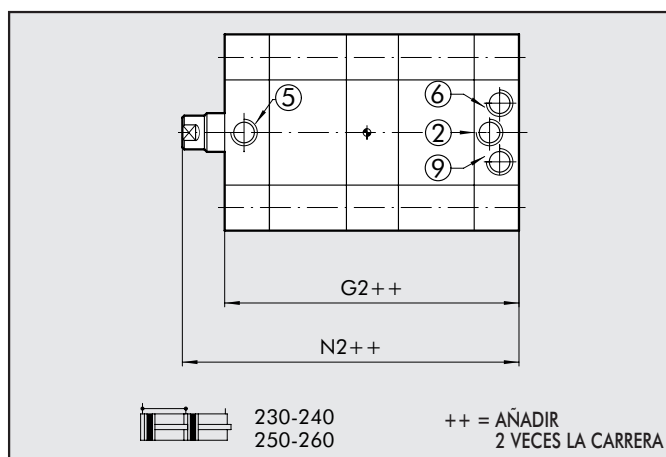
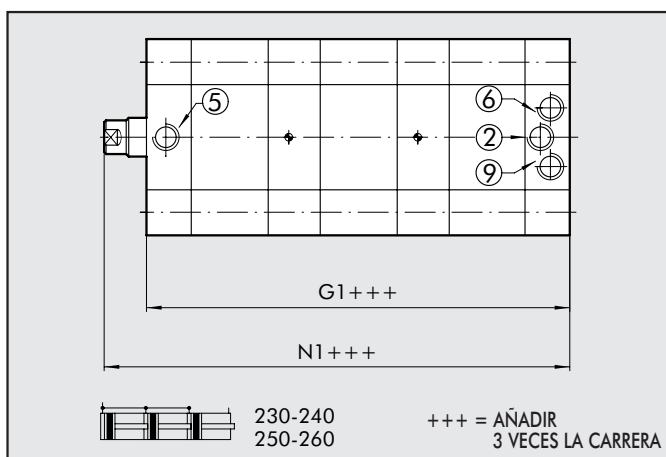

	B		B2	ØC	CH	CH1	D	ØE H9	F	G	G1	G2	H	H1	K	K1	
	A	ISO UNITOP															
Ø 32	47	32.5 ^{+0.1} _{-0.4}	32 ^{+0.4} _{-0.1}	-	12	10	17	48.5	6	4	154	117.5	81	7.5	7.5	-	-
Ø 40	56	38	42	-	12	10	17	57.5	6	4	162.5	123.5	84.5	7.5	7.5	-	-
Ø 50	67	46.5	50	-	16	13	19	69	6	4	163.5	124	85	7.5	7.5	-	-
Ø 63	80	56.5	62	13	16	13	19	82	8	4	182	138	94	7.5	7.5	-	-
Ø 80	102	72	82	17	20	17	24	105	8	4	204.5	155	105.5	8.5	-	10.5	10.5
Ø 100	123	89	103	21	25	22	30	126	8	4	243	184	125.5	10.5	-	14.5	14.5

	O		ØO1		P	Q	R	S
	L	M	ISO	UNITOP				
Ø 32	4	14	M6	M6	5.2	5.2	M10x1.25	22
Ø 40	4.5	14	M6	M6	5.2	5.2	M10x1.25	22
Ø 50	4.5	16	M8	M8	6.2	6.2	M12x1.25	24
Ø 63	5.5	16	M8	M10	6.2	8.5	M12x1.25	24
Ø 80	5.5	20	M10	M10	8.5	8.5	M16x1.5	32
Ø 100	5.5	24	M10	M10	8.5	8.5	M20x1.5	40

DIMENSIONES CILINDRO VARIAS POSICIONES Ø 12÷25 - 3 POSICIONES

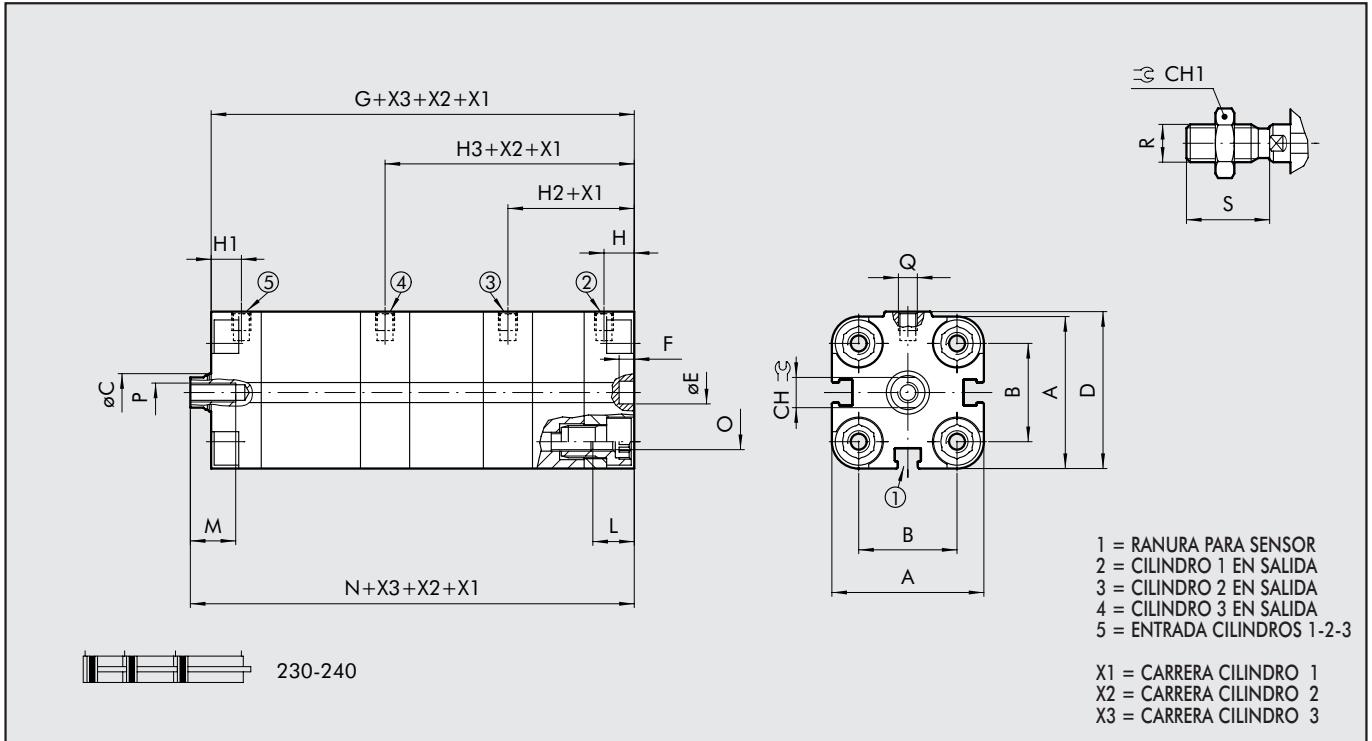

2 POSICIONES

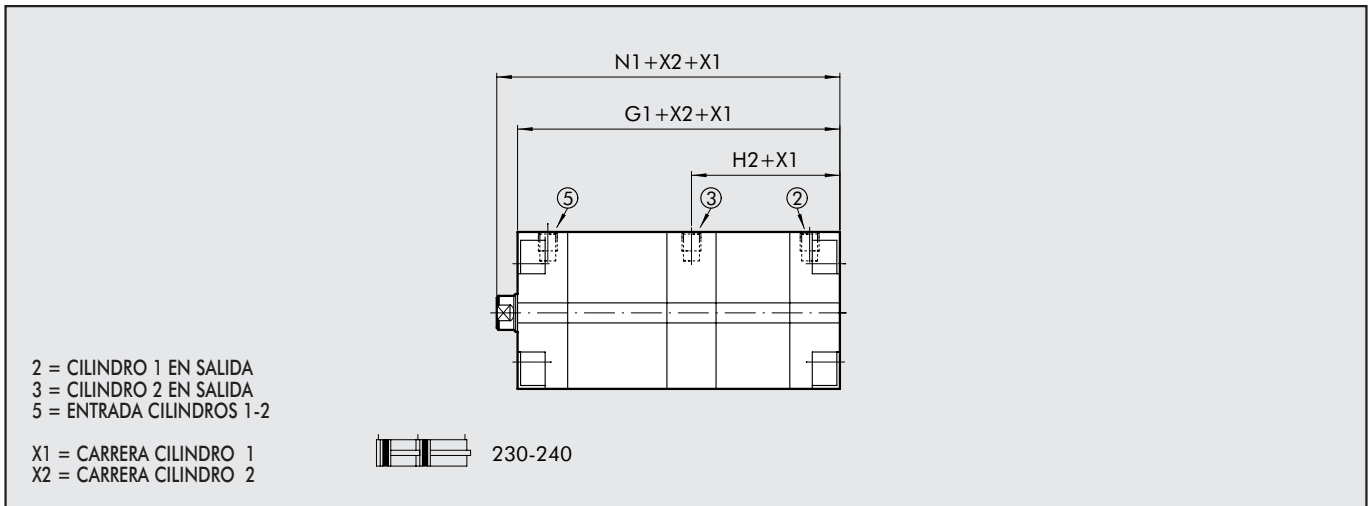

	A	B	ØC	CH	CH1	D	ØEH9	F	G	G1	H	H1	H2	H3	L	M	N	N1	O	P	Q	R	S
Ø 12	29	18	6	5	10	30	6	4	89	63.5	8	8	33.5	59	10	8	93.5	68	M4	M3	M5	M6	16
Ø 16	29	18	8	7	13	30	6	4	89	63.5	8	8	33.5	59	10	10	93.5	68	M4	M4	M5	M8	20
Ø 20*	36.5	22	10	8	17	37.5	6	4	89	63.5	8	8	33.5	59	10	12	93.5	68	M5	M5	M5	M10x1.25	22
Ø 25*	40.5	26	10	8	17	41.5	6	4	92	66	8	8	34	60	10	12	97.5	71.5	M5	M5	M5	M10x1.25	22

*Norma UNITOP

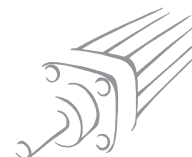

DIMENSIONES CILINDRO VARIAS POSICIONES Ø 32 ÷ 100 - 3 POSICIONES

1 = RANURA PARA SENSOR
 2 = ALIMENTACIÓN CILINDRO 1 SALIDA PARA Ø 32÷63
 3 = ALIMENTACIÓN CILINDRO 2 SALIDA PARA Ø 32÷100
 4 = ALIMENTACIÓN CILINDRO 3 SALIDA PARA Ø 32÷100
 5 = ALIMENTACIÓN CILINDRO ENTRADA PARA Ø 32÷63
 6 = ALIMENTACIÓN CILINDRO ENTRADA PARA Ø 100
 7 = SOLO PARA Ø 63 AL Ø 100
 8 = REBAJE PARA TORNILLO DIN 7984
 9 = ALIMENTACIÓN CILINDRO SALIDA Ø 80÷100

X1 = CARRERA CILINDRO 1
 X2 = CARRERA CILINDRO 2
 X3 = CARRERA CILINDRO 3

230-240
 250-260

2 POSICIONES

2 = ALIMENTACIÓN CILINDRO 1 SALIDA PARA Ø 32÷63
 3 = ALIMENTACIÓN CILINDRO 2 SALIDA PARA Ø 32÷100
 5 = ALIMENTACIÓN CILINDRO ENTRADA 1,2 PARA Ø 32÷63
 6 = ALIMENTACIÓN CILINDRO ENTRADA PARA Ø 100
 9 = ALIMENTACIÓN CILINDRO SALIDA Ø 80÷100

X1 = CARRERA CILINDRO 1
 X2 = CARRERA CILINDRO 2

230-240
 250-260

	A	B		B2	ØC	CH	CH1	D	ØE H9	F	G	G1	H	H1	H2	H3
		ISO	UNITOP													
Ø 32	47	32.5 ^{+0.1}	32 ^{+0.1}	-	12	10	17	48.5	6	4	117.5	81	7.5	7.5	44	80.5
Ø 40	56	38	42	-	12	10	17	57.5	6	4	123.5	84.5	7.5	7.5	46.5	85.5
Ø 50	67	46.5	50	-	16	13	19	69	6	4	124	85	7.5	7.5	47	86
Ø 63	80	56.5	62	13	16	13	19	82	8	4	138	94	7.5	7.5	51.5	95.5
Ø 80	102	72	82	17	20	17	24	105	8	4	155	105.5	8.5	-	58	107.5
Ø 100	123	89	103	21	25	22	30	126	8	4	184	125.5	10.5	-	69.3	128

	K	K1	L	M	N	N1	O		ØO1		P	Q	R	S
							ISO	UNITOP	ISO	UNITOP				
Ø 32	-	-	4	14	123.5	87	M6	M6	5.2	5.2	M6	G1/8	M10x1.25	22
Ø 40	-	-	4.5	14	130	91	M6	M6	5.2	5.2	M6	G1/8	M10x1.25	22
Ø 50	-	-	4.5	16	131.5	92.5	M8	M8	6.2	6.2	M8	G1/8	M12x1.25	24
Ø 63	-	-	5.5	16	145.5	101.5	M8	M10	6.2	8.5	M8	G1/8	M12x1.25	24
Ø 80	10.5	10.5	5.5	20	163	113.5	M10	M10	8.5	8.5	M10	G1/8	M16x1.5	32
Ø 100	14.5	14.5	5.5	24	194	135.5	M10	M10	8.5	8.5	M12	G1/4	M20x1.5	40

ESQUEMA DE FUNCIONAMIENTO

LEYENDA

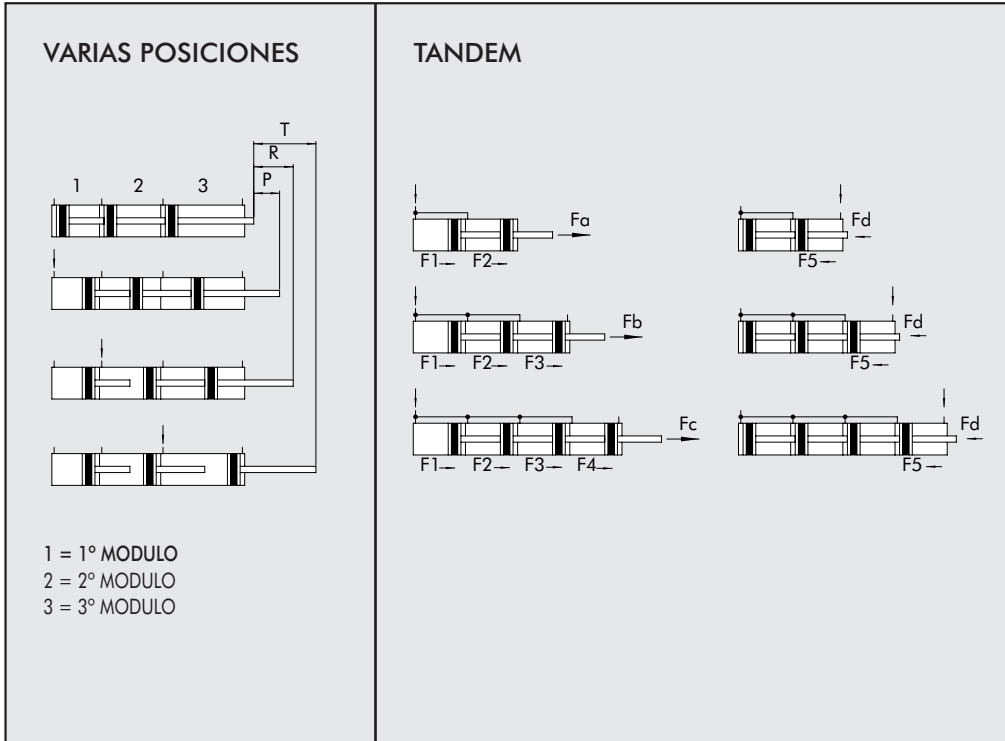

P = Carrera 1° modulo
R = Carrera 2° modulo
T = Carrera 3° modulo

$F_a = F_1 + F_2$ [N]
 $F_b = F_1 + F_2 + F_3$ [N]
 $F_c = F_1 + F_2 + F_3 + F_4$ [N]
 $F_d = F_5$ [N]

CLAVES DE CODIFICACIÓN

CIL	2	3	1	0	2 5	0	0 5 0	X	P						
TIPOLOGIA	DIÁMETRO				CARRERA**		CARRERA								
23 Cil compacto fijaciones UNITOP vástago macho	0 Doble efecto vástago pasante	1 Doble efecto vástago pasante hueco	2 + Doble efecto vástago pasante hueco	3 • Simple efecto vástago retraído	4 • Simple efecto vástago estirado	5 • Simple efecto vástago pasante	6 • + Simple efecto vástago pasante hueco	7 ▽ Doble efect antirrotante	A Doble efecto vástago pasante antirrotación	0 Magnético S No-magnético ▲G No stick slip	12 16 20 25 32 40 50 63 80 100	0 Estándar +A Tandem 2 mod. +B Tandem 3 mod. +C Tandem 4 mod.	•• P Modulo 1° •• R Modulo 2° •• T Modulo 3°	* C Vástago C45 cromado X Vástago y tuerca inox	P Juntas en poliuretano

** Para carreras máximas ver pag. 1.1/36
•• Ver ejemplo debajo

- ◆ Cuando la 4ª cifra esta ocupada por una letra el Ø 100 = A1
 - Codificación valida exclusiva para cilindros diámetros Ø 32 ÷ Ø 100
 - Pueden utilizarse como doble efecto con retorno por muelle
 - ▽ Solo versión 24 y 26 (vástago hembra)
 - + Disponible de Ø = 20
 - ▲ Standard de Ø 12 ÷ 25
 - * Disponible de Ø = 32
- Ejemplo de codificación para un cilindro UNITOP varias posiciones de 2 estadios Ø20 carrera 40+10 (total carrera 50 mm) vástago macho:
 1° ESTADIO (P): 230020P040XP +
 2° ESTADIO (R): 230020R050XP
- Ejemplo de codificación para un cilindro UNITOP varias posiciones de 3 estadios Ø25 carrera 15+30+40 (total carrera 85 mm) vástago macho:
 1° ESTADIO (P): 230025P015XP +
 2° ESTADIO (R): 230025R045XP +
 3° ESTADIO (T): 230025T085XP

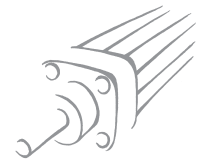

ACCESORIOS

PATA - MOD. A

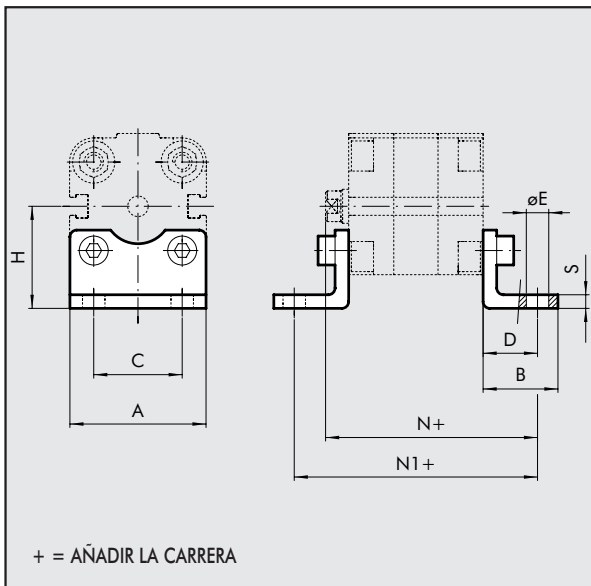

Códigos UNITOP	Ø	A	B	C	D	ØE	H	N	N1	S	Peso [g]
▲ W0950126001	12	30	17.5	18	13	5.5	22	55.5	64	3	26
▲ W0950126001	16	30	17.5	18	13	5.5	22	55.5	64	3	26
W0950206001	20	36	22	22	16	6.6	27	58.5	70	4	46
W0950256001	25	40	22	26	16	6.6	30	58.5	70	4	52
W0950322001	32	45	35	32	24	7	31.9	74.5	92.5	4	76
W0950406001	40	60	28	42	20	9	42.5	72	85.5	5	88
W0950506001	50	68	32	50	24	9	47	77	93.5	6	176
W0950636001	63	84	39	62	27	11	59.5	84.5	104	6	276
W0950806001	80	102	42	82	30	11	65.5	94	116	8	392
W0951006001	100	123	45	103	33	13.5	78	109.5	132.5	8	558

Códigos ISO	Ø	A	B	C	D	ØE	H	N	N1	S	Peso [g]
W0950322001	32	45	35	32	24	7	31.9	74.5	92.5	4	76
W0950402001	40	52	43	36	28	9	36	80	101.5	4	100
W0950502001	50	65	47	45	32	9	45	85	109.5	4	162
W0950632001	63	75	47	50	32	9	50	89.5	114	6	266
W0950802001	80	95	61	63	41	12	63	105	138	6	456
W0951002001	100	115	65	75	41	14	71	117.5	148.5	6	572

Nota: n. 1 pieza por configuración completo de 2 tornillos

▲ Fijaciones no norma UNITOP

CHARNELA HEMBRA - MOD. B

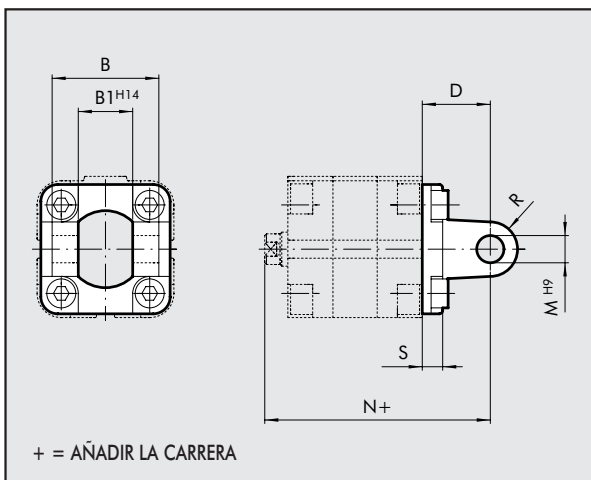

Códigos UNITOP	Ø	B	B1	D	M	N	R	S	Peso [g]
W0950322003	32	45	26	22	10	72.5	11	10	116
W0950406003	40	52	28	25	12	77	12.5	9	184
W0950506003	50	60	32	27	12	80	12.5	11	266
W0950636003	63	70	40	32	16	89.5	15	11	470
W0950806003	80	90	50	36	16	100	15	13	670
W0951006003	100	110	60	41	20	117.5	20	15	1110

Códigos ISO	Ø	B	B1	D	M	N	R	S	Peso [g]
W0950322003	32	45	26	22	10	72.5	11	10	116
W0950402003	40	52	28	25	12	77	13	10	160
W0950502003	50	60	32	27	12	80	13	12	252
W0950632003	63	70	40	32	16	89.5	17	12	394
W0950802003	80	90	50	36	16	100	17	16	670
W0951002003	100	110	60	41	20	117.5	21	16	1085

Nota: servida completa de n. 4 tornillos, n. 4 arandela, n. 2 seeger, n. 1 pasador

CHARNELA MACHO - MOD. BA

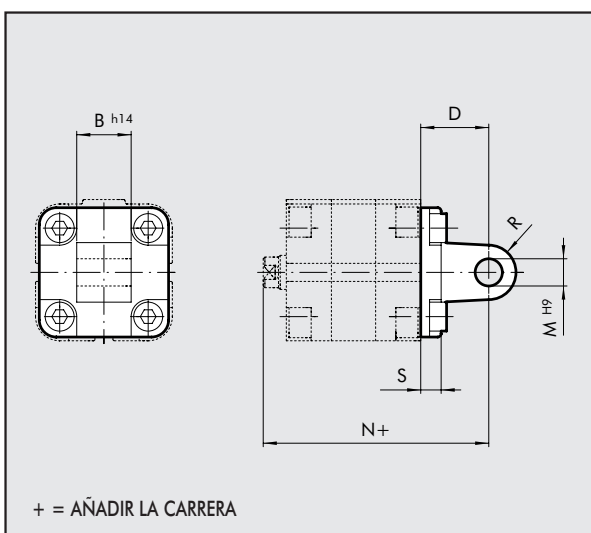

Códigos UNITOP	Ø	B	D	M	N	R	S	Peso [g]
▲ W0950126004	12	12	16	6	58.5	6	6	24
▲ W0950126004	16	12	16	6	58.5	6	6	24
W0950206004	20	16	20	8	62.5	8	6	44
W0950256004	25	16	20	8	62.5	8	6	48

Códigos ISO	Ø	B	D	M	N	R	S	Peso [g]
W0950322004	32	26	22	10	72.5	11	10	94
W0950402004	40	28	25	12	77	13	10	124
W0950502004	50	32	27	12	80	13	12	220
W0950632004	63	40	32	16	89.5	17	12	316
W0950802004	80	50	36	16	100	17	16	578
W0951002004	100	60	41	20	117.5	21	16	850

Nota: servida completa de n. 4 tornillos, n. 4 arandela

▲ Fijaciones no norma UNITOP

BRIDA Ø 12÷25 - MOD. C

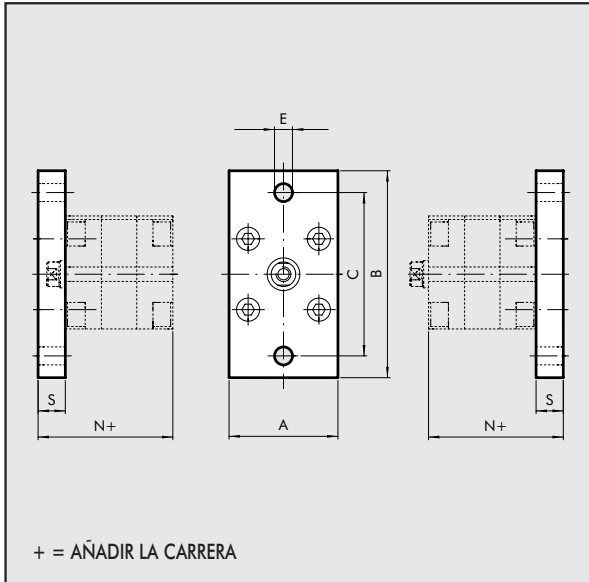

Códigos	Ø	A	B	C	E	N	S	Peso [g]
▲ W0950126002	12	29	55	43	5.5	48	10	112
▲ W0950126002	16	29	55	43	5.5	48	10	112
W0950206002	20	36	70	55	6.6	48	10	184
W0950256002	25	40	76	60	6.6	49.5	10	226

Nota: servida completa de n. 4 tornillos

▲ Fijaciones no norma UNITOP

BRIDA Ø 32÷100 - MOD. C

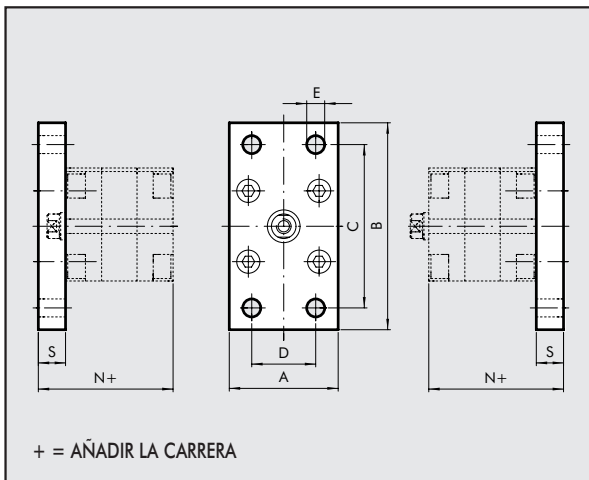

Códigos UNITOP	Ø	A	B	C	D	E	N	S	Peso [g]
W0950322002	32	50	80	64	32	7	54.5	10	246
W0950406002	40	60	102	82	36	9	55.5	10	454
W0950506002	50	68	110	90	45	9	57.5	12	655
W0950636002	63	87	130	110	50	9	65	15	1255
W0950806002	80	107	160	135	63	12	71	15	1900
W0951006002	100	128	190	163	75	14	81.5	15	2700

Códigos ISO	Ø	A	B	C	D	E	N	S	Peso [g]
W0950322002	32	50	80	64	32	7	54.5	10	246
W0950402002	40	55	90	72	36	9	55.5	10	290
W0950502002	50	65	110	90	45	9	57.5	12	522
W0950632002	63	75	120	100	50	9	62	12	670
W0950802002	80	95	153	126	63	12	72	16	1420
W0951002002	100	115	178	150	75	14	82.5	16	2040

Nota: servida completa de n. 4 tornillos

CHARNELA MACHO CON ROTULA - MOD. BAS

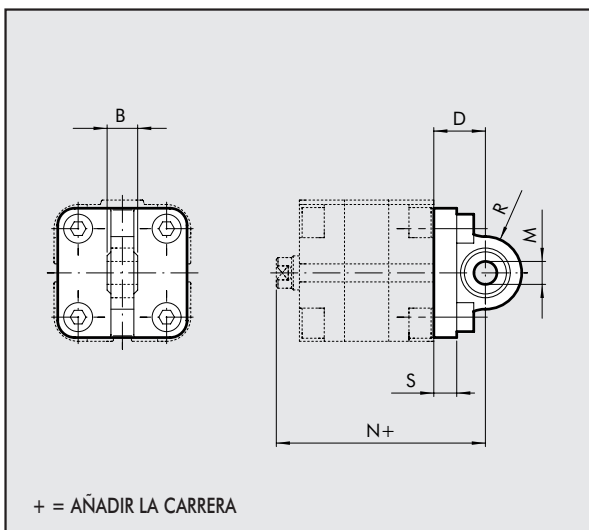

Códigos ISO	Ø	B	D	M	N	R	S	Peso [g]
W0950322006	32	14	22	10	72.5	16	10	106
W0950402006	40	16	25	12	77	19	10	142
W0950502006	50	16	27	12	80	19	12	236
W0950632006	63	21	32	16	89.5	24	12	336
W0950802006	80	21	36	16	100	24	16	572
W0951002006	100	25	41	20	117.5	30	16	840

Nota: servida completa de n. 4 tornillos, n. 4 arandela

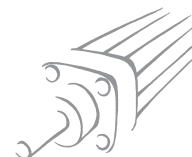

ACCESORIO PARA CILINDRO CONTRAPUESTO

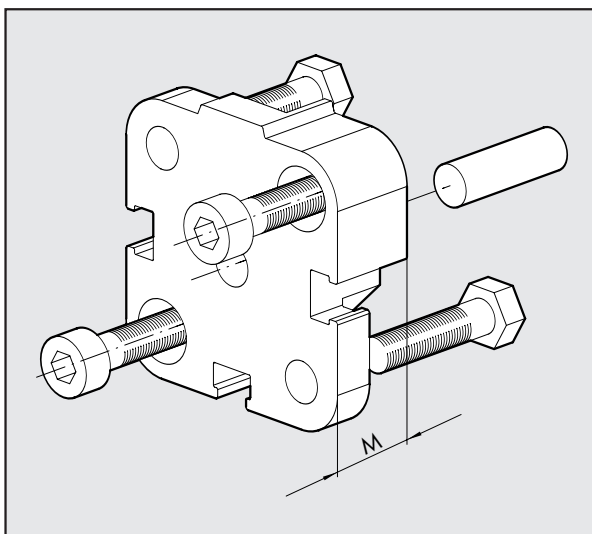

Códigos UNITOP	Códigos ISO	Ø	M	Peso [g]	
				UNITOP	ISO
▲ 0950123060	-	12	12.5	29	-
▲ 0950123060	-	16	12.5	29	-
0950203060	-	20	12.5	45	-
0950253060	-	25	13	57	-
0950323060	0950323060	32	14.5	88	88
0950403060	0950403061	40	14.5	106	106
0950503060	0950503061	50	14.5	172	158
0950633060	0950633061	63	14.5	274	258
0950803060	0950803061	80	16.5	470	452
0951003060	0951003061	100	19.5	826	801

Nota: servida completa de n. 1 eje, n. 4 tornillos

▲ Fijaciones no norma UNITOP

MONTAJE CILINDRO CONTRAPUESTO

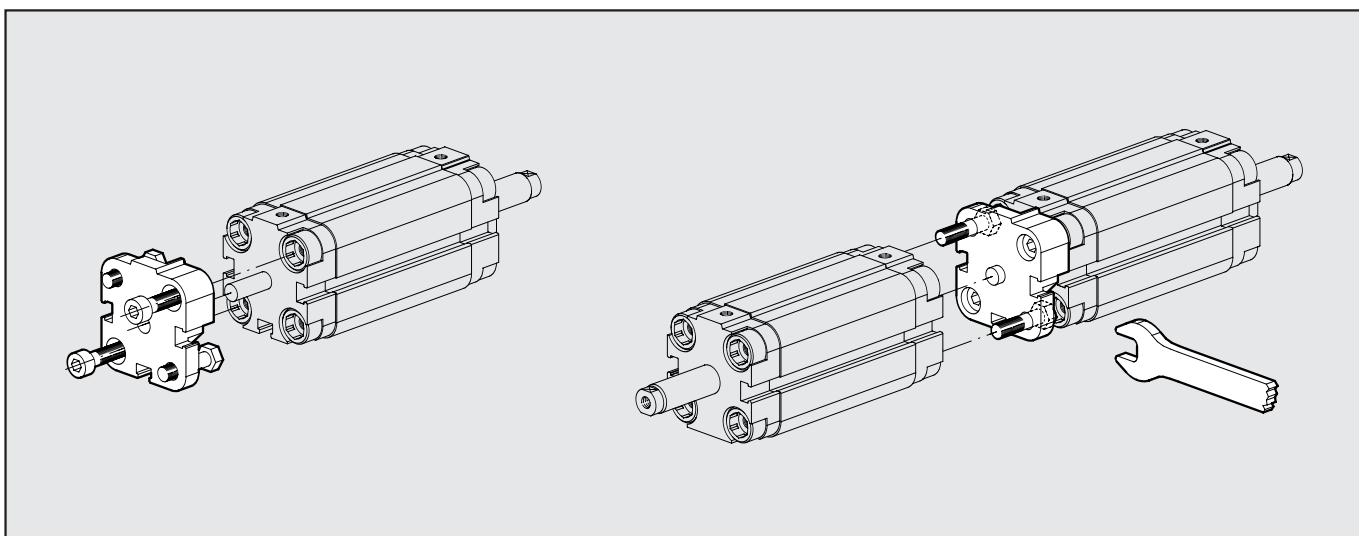

HORQUILLA - MOD. GK-M

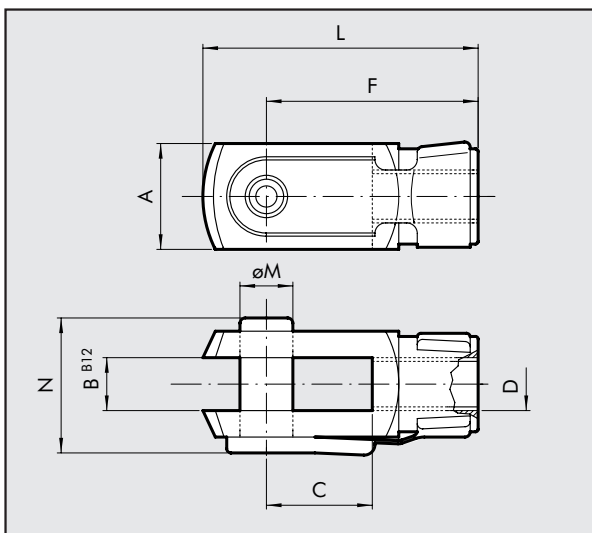

Códigos UNITOP-ISO	Ø	A	B	C	D	F	L	ØM	N	Peso [g]
W0950120020	12	12	6	12	M6	24	31	6	16	20
W0950200020	16	16	8	16	M8	32	42	8	22	48
W0950322020	20	20	10	20	M10x1.25	40	52	10	26	92
W0950322020	25	20	10	20	M10x1.25	40	52	10	26	92
W0950322020	32	20	10	20	M10x1.25	40	52	10	26	92
W0950322020	40	20	10	20	M10x1.25	40	52	10	26	92
W0950402020	50	24	12	24	M12x1.25	48	62	12	32	148
W0950402020	63	24	12	24	M12x1.25	48	62	12	32	148
W0950502020	80	32	16	32	M16x1.5	64	83	16	40	340
W0950802020	100	40	20	40	M20x1.5	80	105	20	48	690

Nota: n. 1 pieza por confección

ROTULA - MOD. GA-M

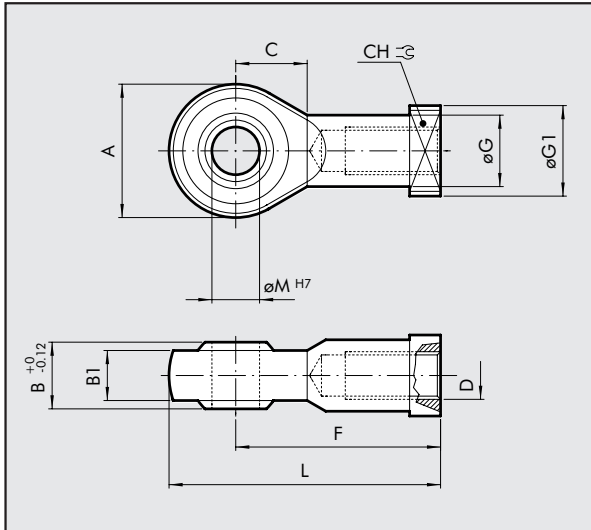

Códigos UNITOP-ISO	Ø	A	B	B1	C	CH	D	F	ØG	ØG1	L	ØM	Peso [g]
W0950120025	12	20	9	6.75	11	11	M6	30	10	13	40	6	28
W0950200025	16	24	12	9	13	14	M8	36	12.5	16	48	8	50
W0950322025	20	28	14	10.5	15	17	M10x1.25	43	15	19	57	10	78
W0950322025	25	28	14	10.5	15	17	M10x1.25	43	15	19	57	10	78
W0950322025	32	28	14	10.5	15	17	M10x1.25	43	15	19	57	10	78
W0950322025	40	28	14	10.5	15	17	M10x1.25	43	15	19	57	10	78
W0950402025	50	32	16	12	17	19	M12x1.25	50	17.5	22	66	12	116
W0950402025	63	32	16	12	17	19	M12x1.25	50	17.5	22	66	12	116
W0950502025	80	42	21	15	23	22	M16x1.5	64	22	27	85	16	226
W0950802025	100	50	25	18	27	30	M20x1.5	77	27.5	34	102	20	404

Nota: n. 1 pieza por confección

CHARNELA JUNTA DE COMPENSACIÓN - MOD. GA

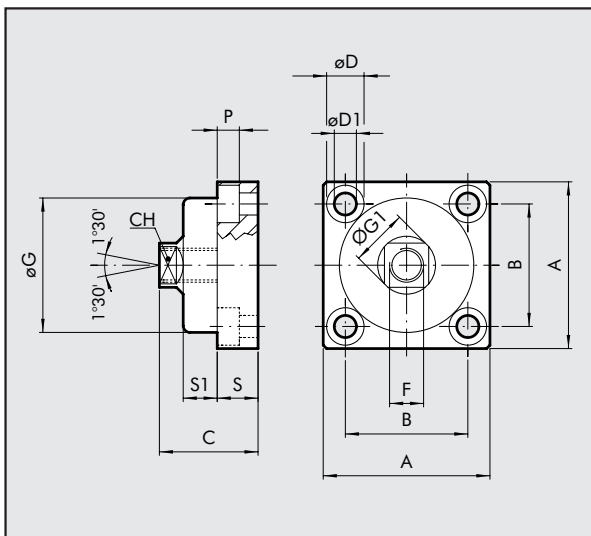

Códigos UNITOP-ISO	Ø	A	B	C	CH	ØD	ØD1	F	ØG	ØG1	P	S	S1	Peso [g]
W0950326021	20	49	36	30	13	11	6.5	M10x1.25	39.5	17	6.5	12	10	172
W0950326021	25	49	36	30	13	11	6.5	M10x1.25	39.5	17	6.5	12	10	172
W0950326021	32	49	36	30	13	11	6.5	M10x1.25	39.5	17	6.5	12	10	172
W0950326021	40	49	36	30	13	11	6.5	M10x1.25	39.5	17	6.5	12	10	172
W0950406021	50	59	42	36	15	14	8.5	M12x1.25	44	19	8.5	15	13.5	286
W0950406021	63	59	42	36	15	14	8.5	M12x1.25	44	19	8.5	15	13.5	286
W0950506021	80	79	58	44	22	17	10.5	M16x1.5	59	26	10.5	20	15	628
W0950806021	100	89	65	51	27	19	12.5	M20x1.5	69	31	12.5	20	20	1200

Nota: n. 1 pieza por confección

CONTRACHARNELA CETOP Ø 32 ÷ 100

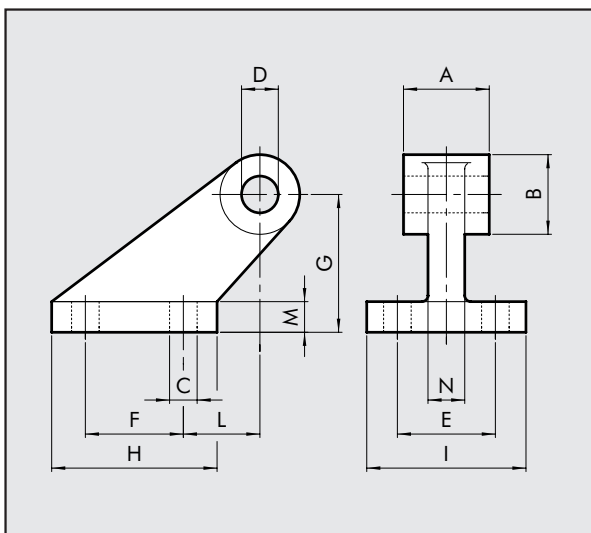

Códigos UNITOP-ISO	Ø	A	B	C	D	E	F	G	H	I	L	M	N	Peso [g]
W0950322008	32	26	19	7	10	25	20	32	37	41	18	8	10	96
W0950402008	40	28	26	9	12	32	32	45	54	52	25	10	12	216
W0950502008	50	32	26	9	12	32	32	45	54	52	25	10	12	212
W0950632008	63	40	33	11	16	40	50	63	75	63	32	12	15	440
W0950802008	80	50	33	11	16	40	50	63	75	63	32	12	15	464
W0951002008	100	60	44	14	20	50	70	90	103	80	40	16	22	985

Nota: servida completa de n. 4 tornillos, n. 4 arandelas



CONTRACHARNELA Ø 16÷25 - MOD. BC

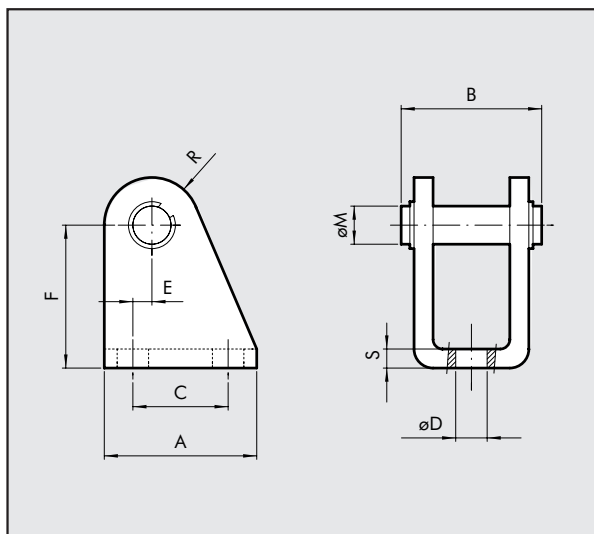

Códigos UNITOP	Ø	A	B	C	ØD	E	F	ØM	R	S	Peso [g]
W0950120005	12	25	25	15	5.5	2	27	6	7	3	40
W0950120005	16	25	25	15	5.5	2	27	6	7	3	40
W0950200005	20	32	30	20	6.5	4	30	8	10	4	78
W0950200005	25	32	30	20	6.5	4	30	8	10	4	78

Nota: servida completa de n. 1 pasador, n. 2 seeger

HOQUILLA AUTOALINEANTE - MOD. GA-K

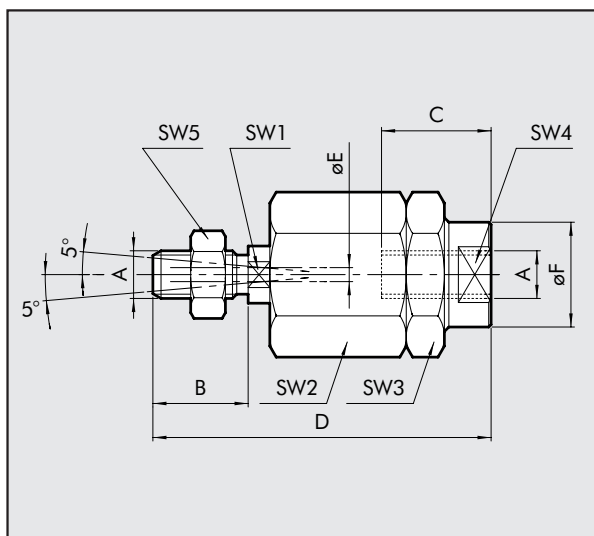

Códigos UNITOP-ISO	Ø	A	B	C	D	ØE	ØF	SW1	SW2	SW3	SW4	SW5	Peso [g]
W0950120030	12	M6	10	10	35	2	8.5	5	13	13	7	10	24
W0950200030	16	M8	20	20	57	4	12.5	7	17	17	11	13	56
W0950322030	20	M10x1.25	20	20	71	4	22	12	30	30	19	17	216
W0950322030	25	M10x1.25	20	20	71	4	22	12	30	30	19	17	216
W0950322030	32	M10x1.25	20	20	71	4	22	12	30	30	19	17	216
W0950322030	40	M10x1.25	20	20	71	4	22	12	30	30	19	17	216
W0950402030	50	M12x1.25	24	20	75	4	22	12	30	30	19	19	220
W0950402030	63	M12x1.25	24	20	75	4	22	12	30	30	19	19	220
W0950502030	80	M16x1.5	32	32	103	4	32	20	41	41	30	24	620
W0950802030	100	M20x1.5	40	40	119	4	32	20	41	41	30	30	680

Nota: n. 1 pieza por confección

KIT MONTAJE CILINDRO TRAMITE RANURA PORTA SENSOR

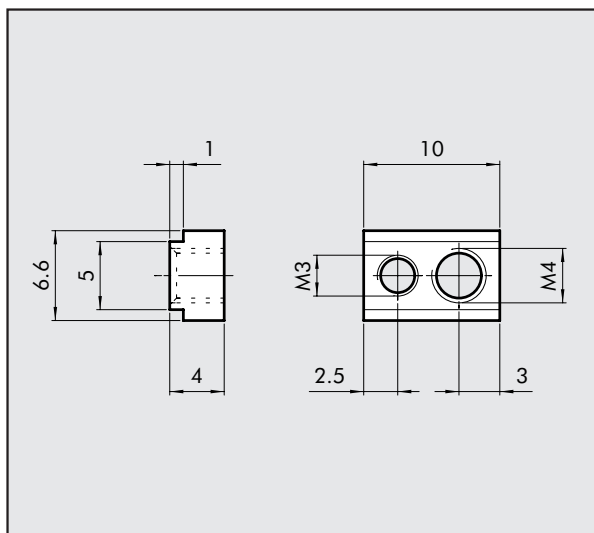

Código	Descripción	Peso [g]
0950003000	PLACA DE FIJACION	2

Nota: servida completo de n. 1 tornillo M3 y n. 1 tornillo M4

SENSOR MAGNETICO INTEGRADO

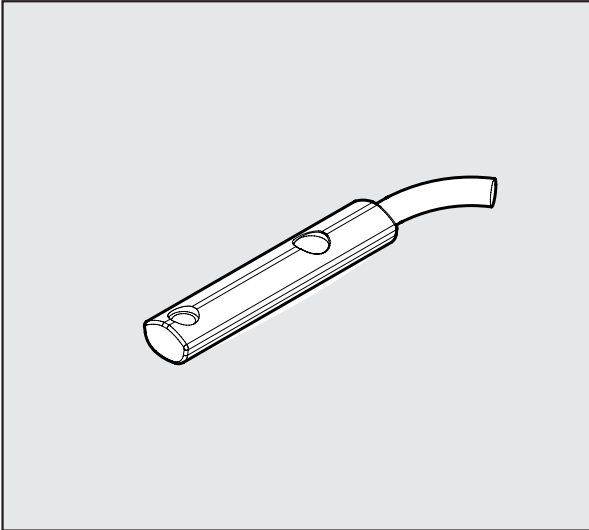

Códigos	Descripción
W0952022180	SENSOR REED INST.VERT.2.5m
W0952028184	SENSOR REED INST.VERT.M8
W0952025390	SENSOR HALL INST.VERT.2.5m
W0952029394	SENSOR HALL INST.VERT.M8
W0952125556	SENSOR HALL INST.VERT.NO 2m ATEX

Este tipo de sensor tiene la característica de poder ser montado en la ranura del sensor directamente desde arriba. Por esto las culatas del cilindro no necesitan de una apertura pasante.

ESQUEMA ELÉCTRICO

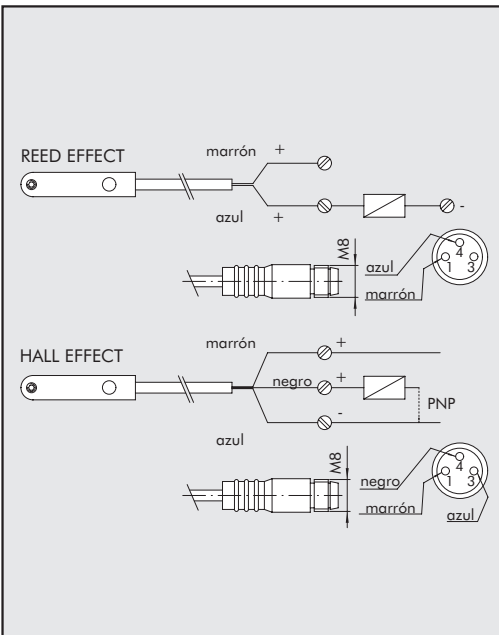

DATOS TÉCNICOS

	Reed	Effetto Hall	ATEX
Tipo contacto	N.O.	N.O.	N.O.
Interruptor	-	PNP	PNP
Tensión de alimentación (Ub)	V 10 ÷ 30 AC/DC	10 ÷ 30 DC	18 ÷ 30 DC
Potencia	W 3 (peak valve=6)	3	≤ 1.7
Variación de tensión	-	≤ 10% di Ub	≤ 10% di Ub
Caída de tensión	V -	≤ 2	≤ 2.2
Consumo	mA -	≤ 10	≤ 10
Corriente de salida	mA ≤ 100	≤ 100	≤ 70
Frecuencia de conmutación	Hz ≤ 400	≤ 5	1000
Protección de corto circuito	-	Si	Si
Sobre tensión	-	Si	Si
Protección al invertir polaridad	-	Si	Si
EMC	EN 60 947-5-2	EN 60 947-5-2	EN 60 947-5-2
Visualización comunicación Led	Amarillo	Amarillo	Amarillo
Sensibilidad magnética	2,8 mT ±25%	2,8 mT ±25%	2.6
Frecuencia	≤ 0,1 mT	≤ 0,1 mT	≤ 0,1 (Ub e ta constanti)
Grado de protección (EN 60529)	IP 67	IP 67	IP 68, IP 69K
Resistencia a la vibración e impactos	30 g, 11 ms, 10÷55 Hz, 1mm	30 g, 11 ms, 10÷55 Hz, 1mm	30 g, 11 ms, 10÷55 Hz, 1mm
Temperatura de trabajo	°C -25 ÷ +75	-25 ÷ +75	-20 ÷ +45
Material cápsula sensor	PA66 + PA6I/6T	PA66 + PA6I/6T	PA
Cable de conexión 2,5m	PVC; 2 x 0,12 mm ²	PVC; 3 x 0,14 mm ²	PVC; 3 x 0,12 mm ²
Cable de conexión con M8x1	Poliuretano; 2 x 0,14 mm ²	Poliuretano; 3 x 0,14 mm ²	-
Numero conductores	2	3	3

RAIL PARA RANURA PORTA-SENSOR

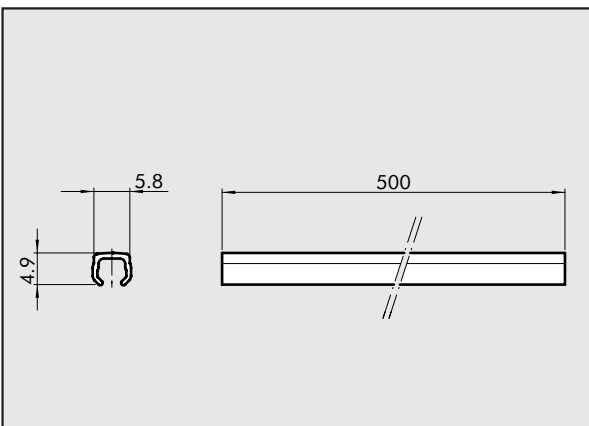

Código	Descripción
W0950000160	RAIL PARA RANURA PORTA-SENSOR

Nota: al código corresponde n. 1 pieza

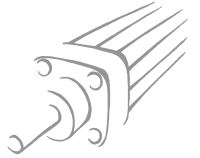

RECAMBIOS

CILINDRO COMPACTO SERIE "CMPC"

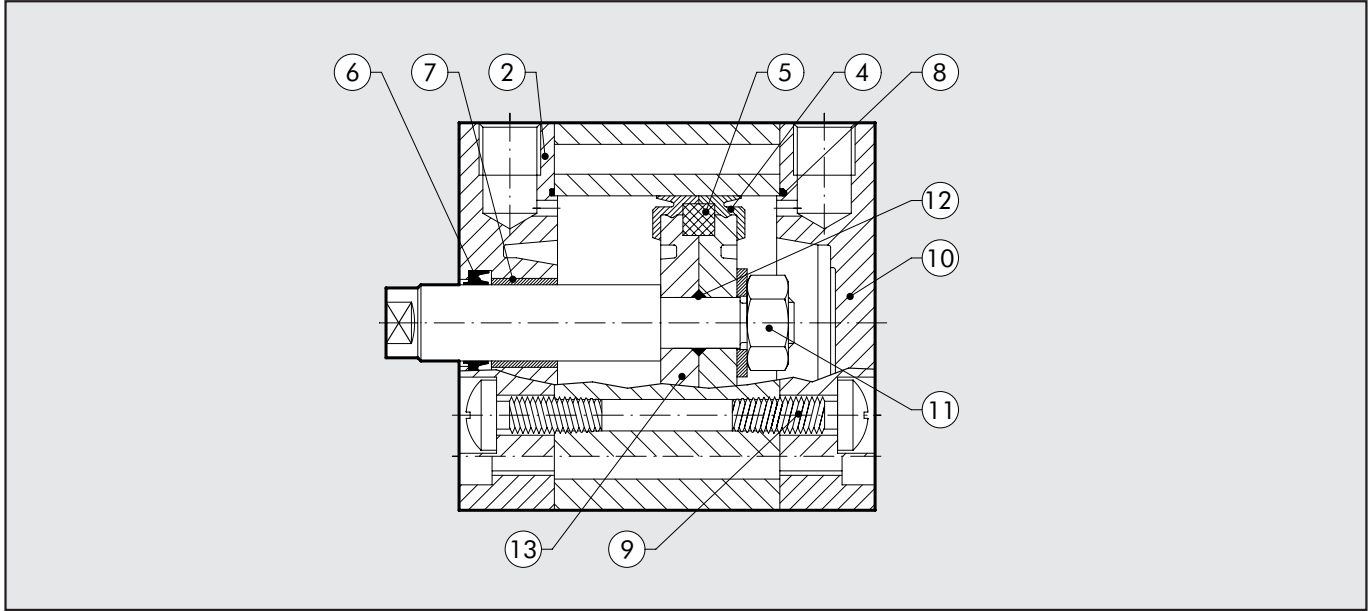

Tipología	Partes	Diámetro	Códigos
Kit completo juntas	④ ⑥ ⑧	∅ 12÷100	009 ... 7001
Kit culata anterior UNITOP	② ⑦ ⑥ ⑧ ⑨	∅ 12÷100	009 ... 7101
Kit culata anterior ISO ∅ 32	② ⑦ ⑥ ⑧ ⑨	∅ 32	0090327101
Kit culata anterior ISO	② ⑦ ⑥ ⑧ ⑨	∅ 40÷100	009 ... 8101
Kit culata posterior UNITOP	⑧ ⑨ ⑩	∅ 12÷100	009 ... 7201
Kit culata posterior ISO ∅ 32	⑧ ⑨ ⑩	∅ 32	0090327201
Kit culata posterior ISO	⑧ ⑨ ⑩	∅ 40÷100	009 ... 8201
Kit piston	④ ⑤ ⑪ ⑫ ⑬	∅ 12÷100	009 ... 7401
Magneto	⑤	∅ 12÷100	009 ... 7501
Kit culata anterior + posterior + piston UNITOP	② ④ ⑤ ⑥ ⑦ ⑧ ⑨ ⑩ ⑪ ⑫ ⑬	∅ 12÷100	009 ... 7901
Kit culata anterior + posterior + piston ISO ∅ 32	② ④ ⑤ ⑥ ⑦ ⑧ ⑨ ⑩ ⑪ ⑫ ⑬	∅ 32	0090327901
Kit culata anterior + posterior + piston ISO	② ④ ⑤ ⑥ ⑦ ⑧ ⑨ ⑩ ⑪ ⑫ ⑬	∅ 40÷100	009 ... 8901