

VÁLVULAS SERIE 70 MECÁNICAS 1/8"

DATOS TÉCNICOS

Rosca válvula	G 1/8
Fuerza de accionamiento a 6 bar:	
• Versión con mando directo	50 N
• Versión servopilotada	6 N
Presión de funcionamiento:	
• Versión con mando directo	2.5 ÷ 10 bar
• Versión servopilotada	Vacío ÷ 10 bar
Temperatura de trabajo	-10° ÷ +60°C
Diámetro nominal	5 mm
Conductancia C	121.43 NI/min · bar
Relación crítica b	0.32 bar/bar
Capacidad a 6 bar ΔP 0.5 bar	400 NI/min
Capacidad a 6 bar ΔP 1 bar	550 NI/min



CLAVES DE CODIFICACIÓN Y CÓDIGOS DE PEDIDO

M	E	V	2	3	T	A	S	N	C	
FAMILIA		DIMENSIÓN	FUNCIÓN		ACCION. 14		ACCION. 12		OTRAS DESCRIPCIONES	
MEW	Valv. mecánicas	2 1/8"	3	3/2	TA	Puntal	S	Resorte mecánico	NC	Norm. cerrada 5/2
			5	5/2	BR	Rodillo bid.	A	Resorte Neumomecánico*	OO	
					UR	Rodillo unid.				
					TS	Puntal sensible				
					RS	Rodillo sensible				
					AS	Antena sensible				
					LL	Palanca rodillo				

PUNTAL 3/2 1/8"

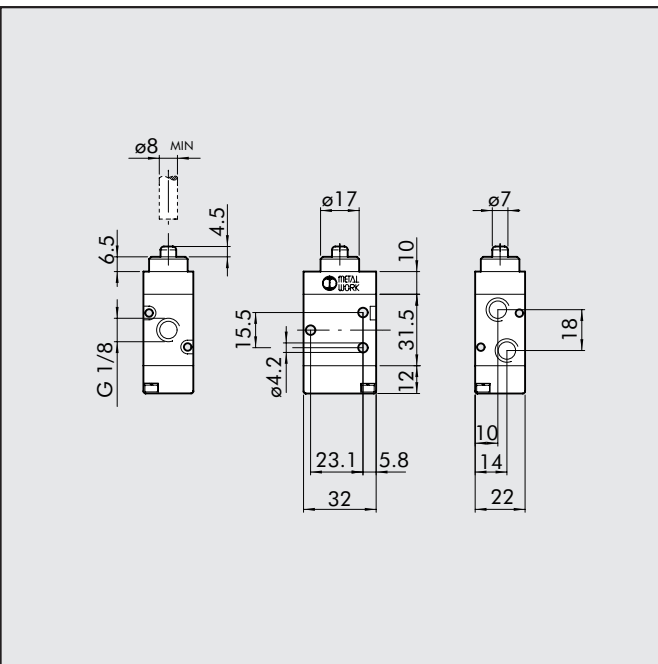

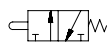
Símbolo	Referencia	Codice	Peso [g]
	MEV 23 TAS NC	7001000100	88

PUNTAL 5/2 1/8"

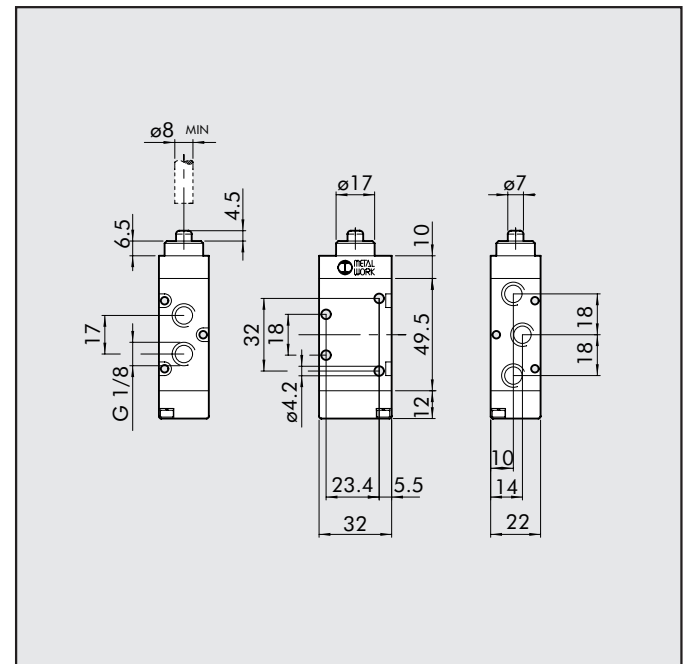

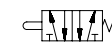
Símbolo	Referencia	Código	Peso [g]
	MEV 25 TAS OO	7001000110	114

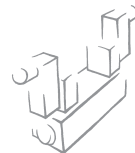

PALANCA RODILLO 3/2 1/8"

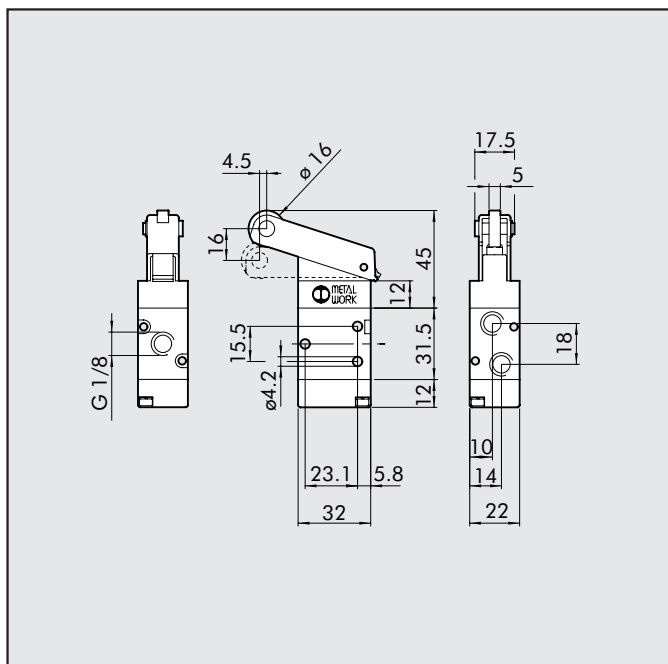

Símbolo	Referencia	Código	Peso [g]
	MEV 23 BRS NC	7001000500	130

PALANCA RODILLO 5/2 1/8"

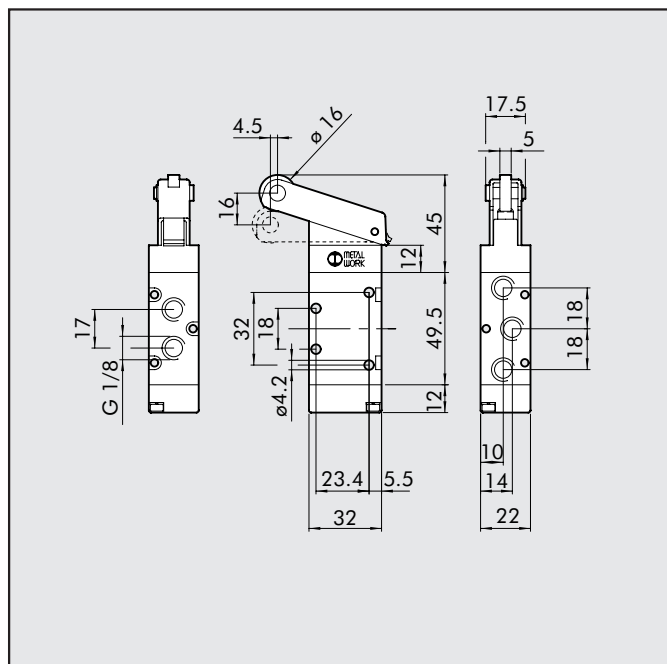

Símbolo	Referencia	Código	Peso [g]
	MEV 25 BRS OO	7001000510	156

PALANCA RODILLO UNIDIRECCIONAL 3/2 1/8"

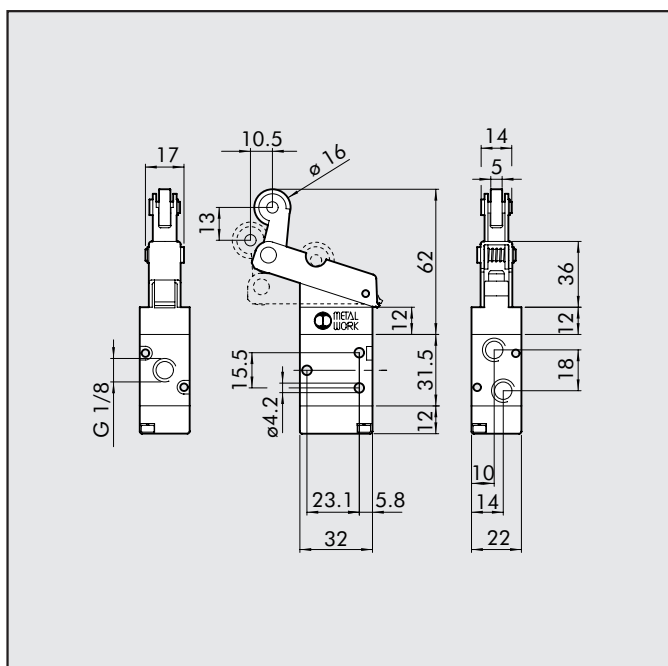

Símbolo	Referencia	Código	Peso [g]
	MEV 23 URS NC	7001000600	136

PALANCA RODILLO UNIDIRECCIONAL 5/2 1/8"

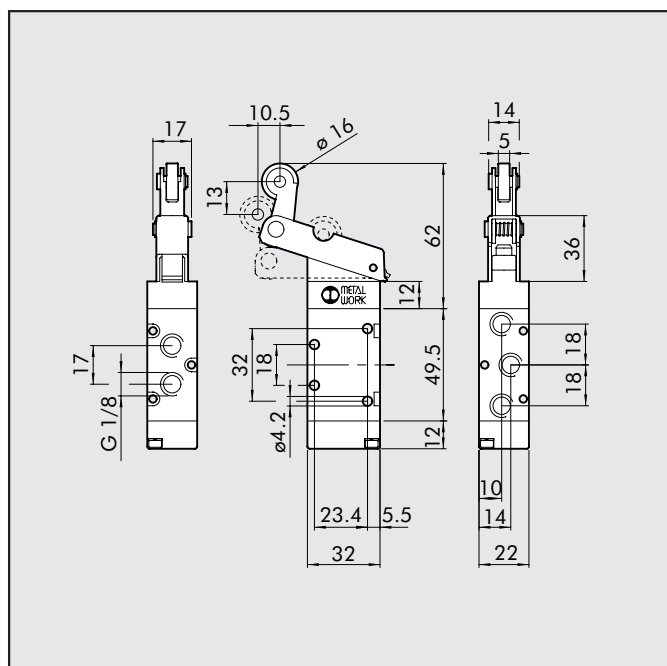

Símbolo	Referencia	Código	Peso [g]
	MEV 25 URS OO	7001000610	162

PUNTAL SERVOPILOTADO 3/2 NC 1/8"

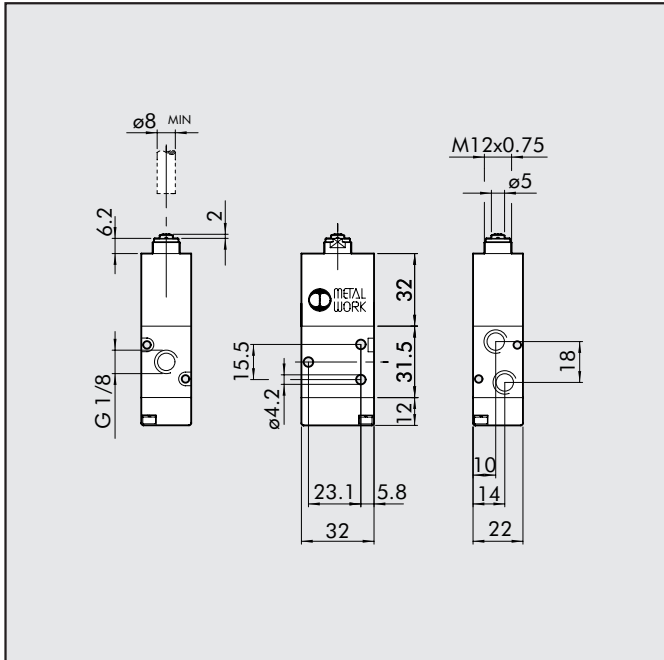

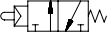
Símbolo	Referencia	Código	Peso [g]
	MEV 23 TSS NC	7001000200	126

PUNTAL SERVOPILOTADO 5/2 1/8"

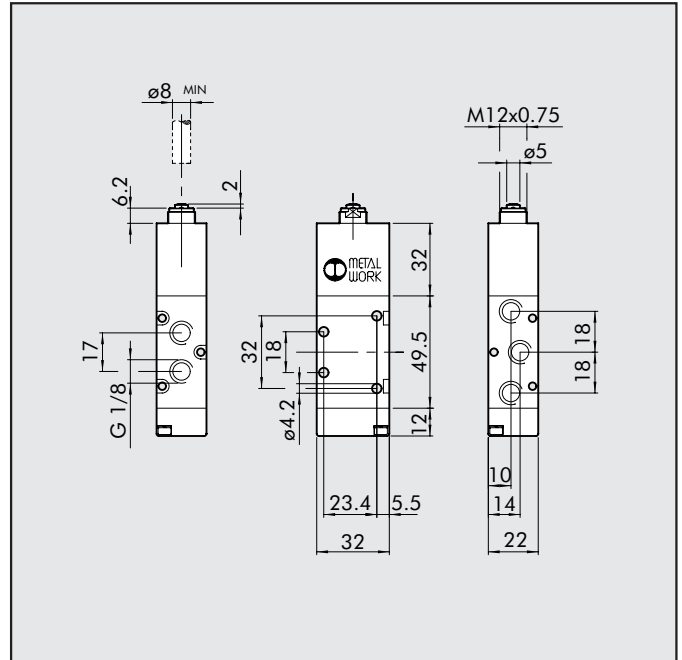

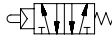
Símbolo	Referencia	Código	Peso [g]
	MEV 25 TSS OO	7001000210	152

PALANCA RODILLO SERVOPILOTADA 3/2 NC 1/8"

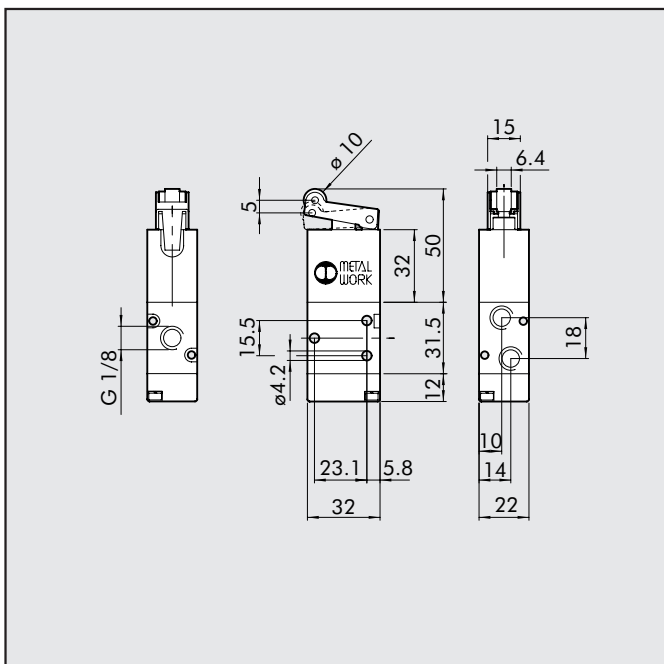

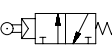
Símbolo	Referencia	Código	Peso [g]
	MEV 23 RSS NC	7001000400	138

PALANCA RODILLO SERVOPILOTADA 5/2 1/8"

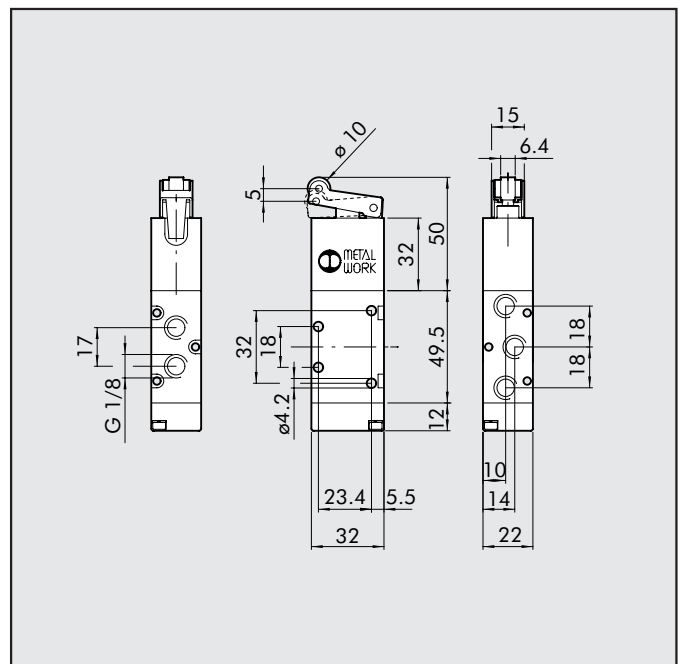

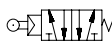
Símbolo	Referencia	Código	Peso [g]
	MEV 25 RSS OO	7001000410	164

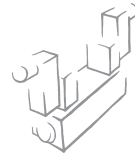

ANTENA SERVOPILOTADA 3/2 NC 1/8"

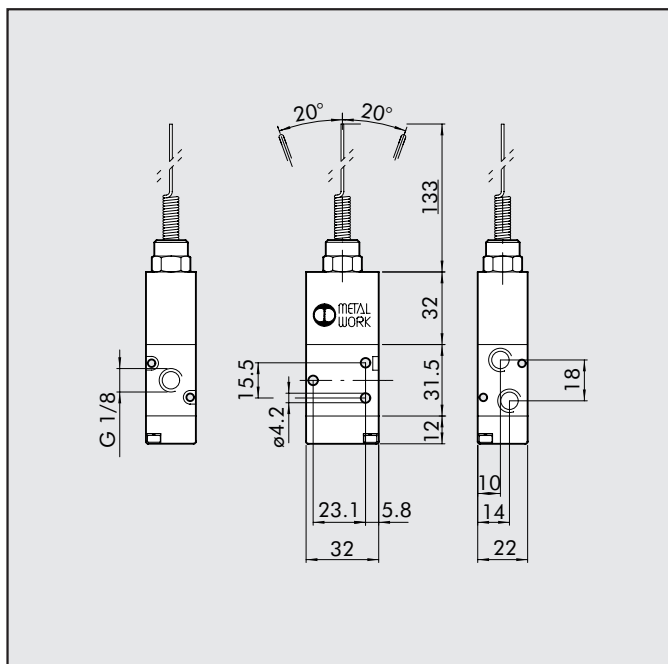

Simbolo	Referencia	Código	Peso [g]
	MEV 23 ASS NC	7001000700	142

ANTENA SERVOPILOTADA 5/2 1/8"

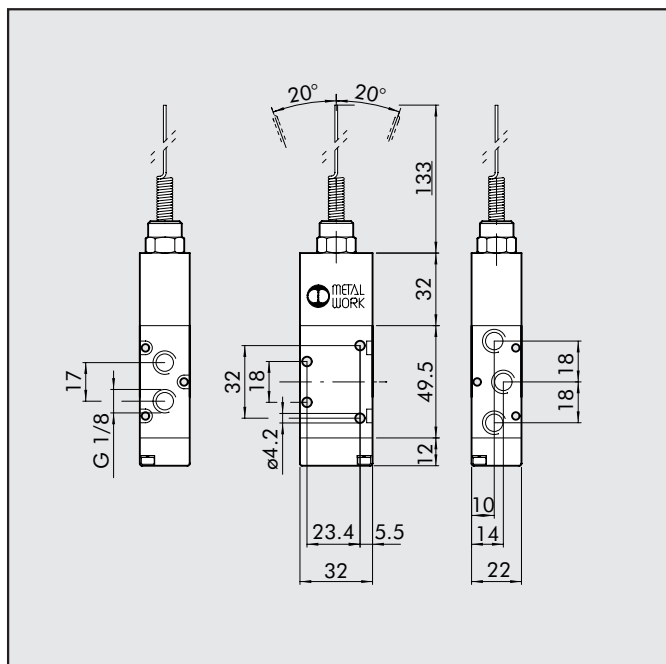

Simbolo	Referencia	Código	Peso [g]
	MEV 25 ASS OO	7001000710	168

PALANCA RODILLO 3/2 1/8"

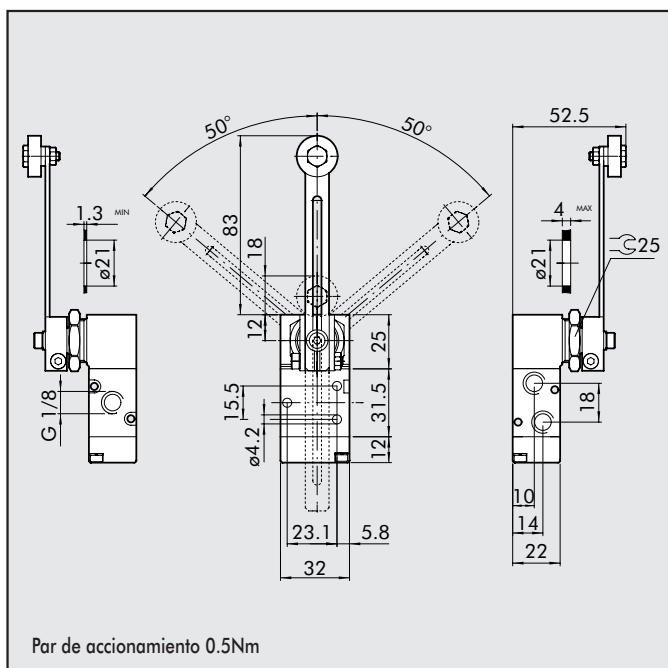

Par de accionamiento 0.5Nm

Simbolo	Referencia	Código	Peso [g]
	MEV 23 LLS NC	7001000900	189

PALANCA RODILLO 5/2 1/8"

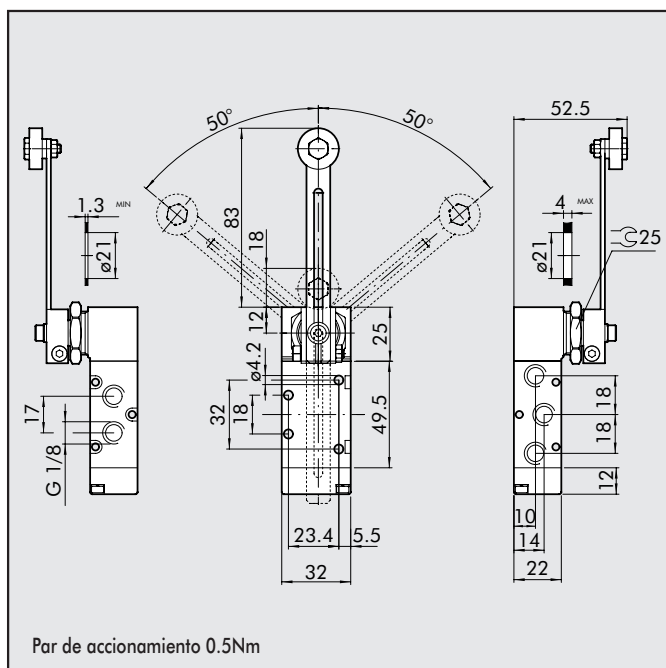

Par de accionamiento 0.5Nm

Simbolo	Referencia	Código	Peso [g]
	MEV 25 LLS OO	7001000910	216